



Applies To: **2000 Accord EX L4** – ALL (with cloth interior only)

**October 22, 2002**

## SRS Indicator On With DTC 9-3 or Driver's Seat Belt Buckle Replacement (Supersedes 01-055, dated July 3, 2001)

### SYMPTOM

The SRS indicator remains on, and DTC 9-3 (faulty driver's seat belt buckle switch) is stored.

### PROBABLE CAUSE

The driver's side seat belt buckle harness may be pinched underneath the center cover, or the harness may be misrouted inside the center cover.

### CORRECTIVE ACTION

Replace the seat belt assembly, and route the seat belt harness as indicated in the REPAIR PROCEDURE.

Use this service bulletin information for the proper harness routing if you have to replace a driver's side seat belt buckle for any reason.

### PARTS INFORMATION

Left Front Seat Belt Buckle Set

4-door:

Dark Lapis

P/N 04816-S4K-A41ZA, H/C 6604151

P/N 04816-S84-A30ZA, H/C 6209126

P/N 04816-S84-A40ZA, H/C 6209159

Quartz Gray

P/N 04816-S4K-A41ZB, H/C 6604169

P/N 04816-S84-A30ZB, H/C 6209134

P/N 04816-S84-A40ZB, H/C 6209167

Medium Taupe

P/N 04816-S4K-A41ZC, H/C 6604177

P/N 04816-S84-A30ZC, H/C 6209142

P/N 04816-S84-A40ZC, H/C 6209175

2-door:

Charcoal

P/N 04816-S82-305ZA, H/C 6500466

Ivory

P/N 04816-S82-305ZC, H/C 6500482

### WARRANTY CLAIM INFORMATION

**In warranty:** The normal warranty applies.

OP #	Description	FRT
856503	Retrieve and clear DTC with PGM Tester	0.3
855185	Replace seat belt buckle assembly	0.4

Failed Part: P/N 04816-S84-A30ZC  
H/C 6209142

Defect Code: L32

Contention Code: B03

Skill Level: Repair Technician

**Out of warranty:** Any repair performed after warranty expiration may be eligible for goodwill consideration by the District Parts and Service Manager or your Zone Office. You must request consideration, and get a decision, before starting work.

### DIAGNOSIS

Inspect the seat belt buckle wire harness inside the corrugated tube. The wires can be damaged even if damage to the corrugated tubing is not visually evident.

- If damaged, go to REPAIR PROCEDURE.
- If not damaged, go to the appropriate troubleshooting procedure in the the service manual.

### REPAIR PROCEDURE

1. Make sure you have the anti-theft code for the radio, and write down the customer's radio station presets.
2. Move the driver's seat to the highest position.
3. Disconnect the negative battery cable, and wait at least 3 minutes before continuing.
4. Remove the seat track end covers (see page 20-99 in the service manual).
5. Remove the four bolts that secure the seat to the floor.
6. Lean back the driver's seat, and inspect all SRS-related connectors underneath the seat. Verify that all of the harness connector(s) and terminals are seated properly.
  - If all connectors and terminals are seated properly, go to step 7.
  - If any connector or terminal is not seated correctly, repair it so that it is seated correctly. Return the seat to the upright position, and connect the negative battery cable. Clear the DTC from the SRS main unit with the PGM Tester, turn the ignition switch to ON (II), and latch and unlatch the buckle to confirm that the code does not return.
    - If DTC 9-3 shows up again, disconnect the negative battery cable, and wait at least 3 minutes, then go to step 7.
    - If DTC 9-3 does not show up again, go to step 20.

7. Remove the bracket cover.

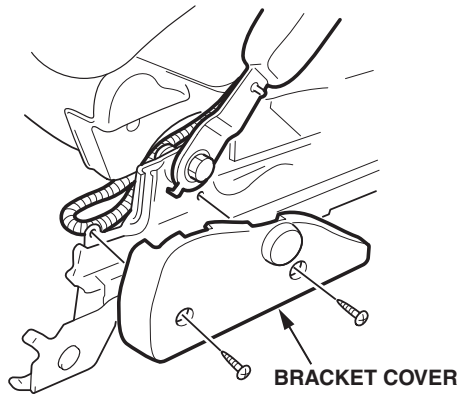

8. Inspect the seat belt buckle harness at the rear inside corner of the seat rail near the area where the seat belt buckle is anchored to the seat frame.

- If the harness is correctly routed outside the center cover, go to step 16.
- If the harness is incorrectly routed inside the center cover, go to step 9.

**Correct:**

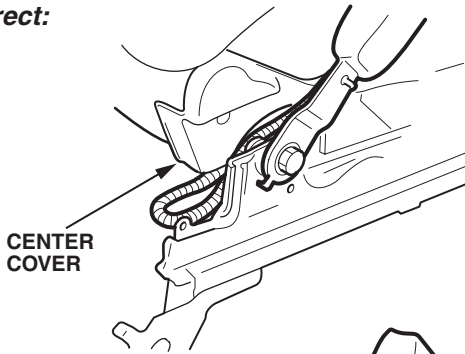

**Incorrect:**

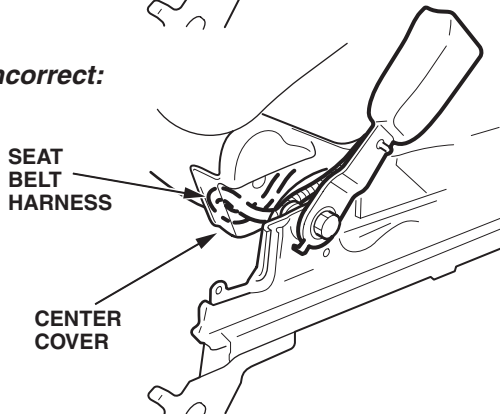

9. Disconnect the seat harness connector(s), and detach the harness clip(s).

10. Carefully remove the seat through the front door opening.

11. Remove the center anchor bolt.

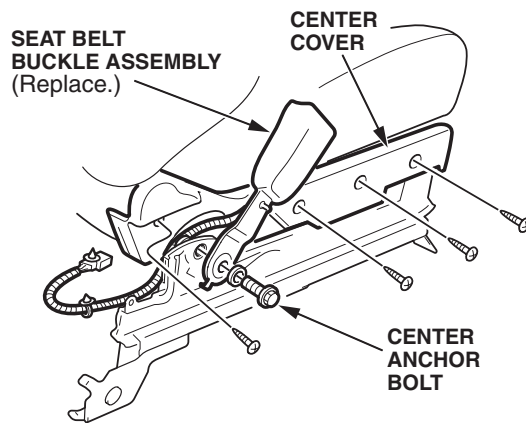

12. To avoid distorting the center cover, remove it; then remove the seat belt buckle harness.

13. Remove and discard the old seat belt buckle assembly.

14. Install the center cover.

15. Install the new seat belt buckle assembly, and carefully route the harness below and outside the center cover. Torque the center anchor bolt to 32 N·m (24 lb-ft).

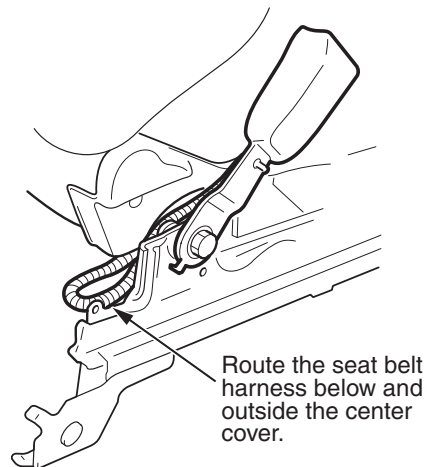

16. Install the bracket cover.

17. Place the seat into position in the vehicle, and connect the harness connector(s).

18. Connect the negative battery cable.

19. Clear the SRS DTC(s) using the PGM Tester, and verify proper operation of the SRS warning indicator.

20. Install the four bolts that secure the seat to the floor. Torque the bolts to 34 N·m (25 lb-ft).

21. Install the seat track end covers.

22. Enter the radio station presets, and set the clock.