

Fuel Supply System

PGM-FI Main Relay Circuit Troubleshooting

1. Turn the ignition switch OFF, then disconnect the PGM-FI main relay 7P connector.
2. Check for continuity between body ground and PGM-FI main relay 7P connector terminal No. 3.

PGM-FI MAIN RELAY 7P CONNECTOR

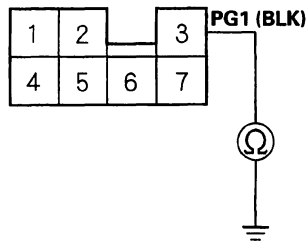

Wire side of female terminals

Is there continuity?

YES – Go to step 3.

NO – Repair open in the wire between the PGM-FI main relay and G101. ■

3. Measure voltage between body ground and PGM-FI main relay 7P connector terminal No. 7.

PGM-FI MAIN RELAY 7P CONNECTOR

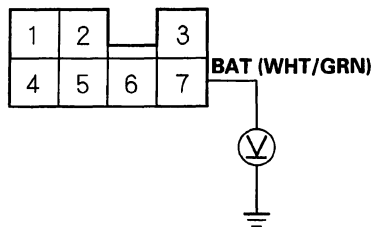

Wire side of female terminals

Is there battery voltage?

YES – Go to step 5.

NO – Go to step 4.

4. Check for a blown ACG S (15A) fuse in the under-hood fuse/relay box.

Is the fuse blown?

YES – Repair the short in the wire between the PGM-FI main relay and the ACG S (15A) fuse. ■

NO – Repair the open in the wire between the PGM-FI main relay and the ACG S (15A) fuse. ■

5. Turn the ignition switch ON (II), and measure voltage between body ground and PGM-FI main relay 7P connector terminal No. 5.

PGM-FI MAIN RELAY 7P CONNECTOR

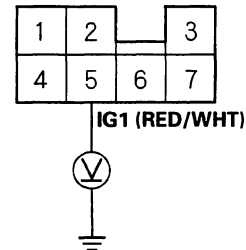

Wire side of female terminals

Is there battery voltage?

YES – Go to step 7.

NO – Go to step 6.

6. Check for a blown No. 1 FUEL PUMP (15A) fuse in the driver's under-dash fuse/relay box.

Is the fuse blown?

YES – Repair the short in the wire between the PGM-FI main relay and the No. 1 FUEL PUMP (15A) fuse. ■

NO – Repair the open in the wire between the PGM-FI main relay and the No. 1 FUEL PUMP (15A) fuse. ■



7. Push the clutch pedal in, or shift to Park, then turn the ignition switch to the START (III) position, and measure voltage between body ground and PGM-FI main relay 7P connector terminal No. 2.

PGM-FI MAIN RELAY 7P CONNECTOR

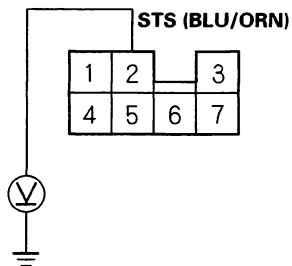

Wire side of female terminals

Is there battery voltage?

YES – Go to step 9.

NO – Go to step 8.

8. Check for a blown No. 13 STARTER SIGNAL (7.5A) fuse in the driver's under-dash fuse/relay box.

Is the fuse blown?

YES – Repair the short in the wire between the PGM-FI main relay and the No. 13 STARTER SIGNAL (7.5A) fuse. ■

NO – Repair the open in the wire between the PGM-FI main relay and the No. 13 STARTER SIGNAL (7.5A). ■

9. Turn the ignition switch OFF, and disconnect ECM/PCM connector A (32P).

10. Check for continuity between PGM-FI main relay 7P connector terminal No. 1 and ECM/PCM connector terminal A15.

PGM-FI MAIN RELAY 7P CONNECTOR

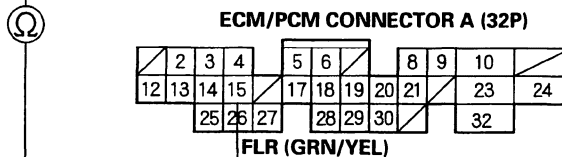
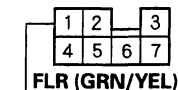

Wire side of female terminals

Is there continuity?

YES – Go to step 11.

NO – Repair open in the wire between the PGM-FI main relay and the ECM/PCM (A15). ■

11. Reconnect ECM/PCM connector A (32P) and the PGM-FI main relay 7P connector.

12. Turn the ignition switch ON (II), and measure voltage between ECM/PCM connector terminals B1 and B20, and between B9 and B20.

ECM/PCM CONNECTOR B (25P)

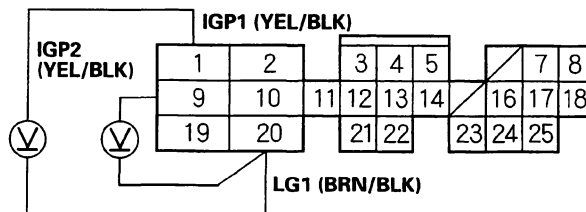

Wire side of female terminals

Is there battery voltage?

YES – Go to step 13.

NO – Check for an open in the wires between the PGM-FI main relay and the ECM/PCM (B1, B9). If the wires are OK, replace the PGM-FI main relay. ■

(cont'd)

Fuel Supply System

PGM-FI Main Relay Circuit Troubleshooting (cont'd)

13. Turn the ignition switch OFF, then ON (II) again, and measure voltage between the ECM/PCM connector terminals A15 and B2 within the first 2 seconds after the ignition switch is turned ON (II).

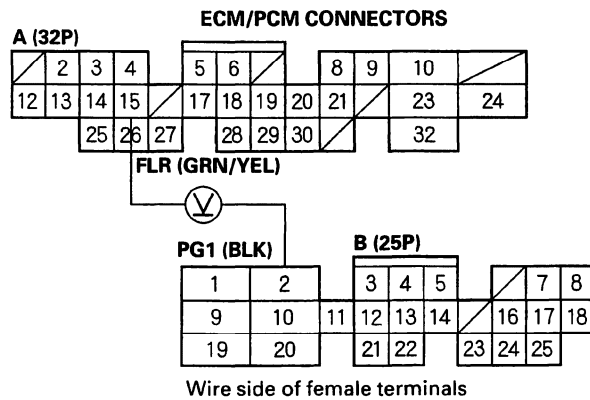

Is there 1.0 V or less?

YES – The PGM-FI main relay may be faulty. Go to step 14.

NO – Substitute a known-good ECM/PCM and recheck (see page 11-5). If the prescribed voltage is now available, replace the original ECM/PCM. ■

14. Remove the PGM-FI main relay.

15. Connect battery power to the PGM-FI main relay 7P connector terminal No. 2, and connect ground to the PGM-FI main relay 7P connector terminal No. 1. Then check for continuity between the PGM-FI main relay 7P connector terminals No. 5 and No. 4.

NOTE: Use the terminal numbers shown. Ignore the terminal numbers molded into the relay.

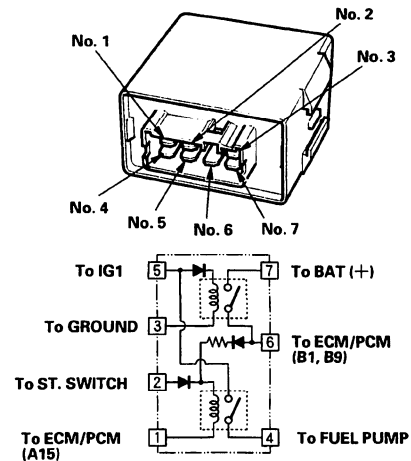

Is there continuity?

YES – Go to step 16.

NO – Replace the PGM-FI main relay and retest. ■

16. Connect battery power to the PGM-FI main relay 7P connector terminal No. 5, and connect ground to the PGM-FI main relay 7P connector terminal No. 3. Then check for continuity between the PGM-FI main relay 7P connector terminals No. 7 and No. 6.

Is there continuity?

YES – Go to step 17.

NO – Replace the PGM-FI main relay and retest. ■

17. Connect battery power to the PGM-FI main relay 7P connector terminal No. 6, and connect ground to the PGM-FI main relay 7P connector terminal No. 1. Then check for continuity between the PGM-FI main relay 7P connector terminals No. 5 and No. 4.

Is there continuity?

YES – The PGM-FI main relay is OK. ■

NO – Replace the PGM-FI main relay and retest. ■