

How To Use This Manual

Five-Step Troubleshooting

1. Verify The Complaint

Turn on all the components in the problem circuit to check the accuracy of the customer complaint. Note the symptoms. Do not begin disassembly or testing until you have narrowed down the problem area.

2. Analyze The Schematic

Look up the schematic for the problem circuit. Determine how the circuit is supposed to work by tracing the current paths from the power source through the circuit components to ground. Also, trace circuits that share wiring with the problem circuit. The names of circuits that share the same fuse, ground, or switch, and so on, are referred to in each circuit schematic. Try to operate any shared circuits you didn't check in step 1. If the shared circuits work, the shared wiring is OK, and the cause must be in the wiring used only by the problem circuit. If several circuits fail at the same time, the fuse or ground is a likely cause.

Based on the symptoms and your understanding of the circuit's operation, identify one or more possible causes.

3. Isolate The Problem By Testing The Circuit

Make circuit tests to check the diagnosis you made in step 2. Keep in mind that a logical, simple procedure is the key to efficient troubleshooting. Test for the most likely cause of failure first. Try to make tests at points that are easily accessible.

4. Fix The Problem

Once the specific problem is identified, make the repair. Be sure to use proper tools and safe procedures.

5. Make Sure The Circuit Works

Turn on all components in the repaired circuit in all modes to make sure you've fixed the entire problem. If the problem was a blown fuse, be sure to test all of the circuits on that fuse. Make sure no new problems turn up and the original problem does not recur.

Test Equipment

CAUTION:

Most circuits include solid-state devices. Test the voltages in these circuits only with a 10-megaohm or higher impedance digital multimeter. Never use a test light or analog meter on circuits that contain solid-state devices. Damage to the devices may result.

Test Light and DVOM

On circuits without solid-state devices, use a test light to check for voltage. A test light is made up of a 12 volt bulb with a pair of leads attached. After grounding one lead, touch the other lead to various points along the circuit where voltage should be present. The bulb will go on if there is voltage at the point being tested. If you need to know how much voltage is present, use a digital volt/ohmmeter (DVOM).

Self-Powered Test Light and DVOM

Use a self-powered test light to check for continuity. This tool is made up of a light bulb, battery, and two leads. To test it, touch the leads together: the light should go on.

Use a self-powered test light only on an unpowered circuit. First, disconnect the battery, or remove the fuse that feeds the circuit you are working on. Select two points in the circuit between which you want to check continuity. Connect one lead of the self-powered test light to each point. If there is continuity, the test light's circuit will be completed, and the light will go on.

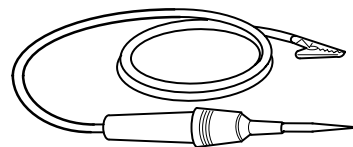

SELF-POWERED TEST LIGHT

If, in addition, you need to know exactly how much resistance there is between two points, use a digital volt/ohmmeter (DVOM).



How To Use This Manual

– Test Equipment

In the “OHMS” range, the DVOM will measure resistance between two points along a circuit. Low resistance means good continuity.

Diodes and solid-state devices in a circuit can make a DVOM give a false reading. To check a reading, reverse the leads, and take a second reading. If the readings differ, the component is affecting the measurement.

Jumper Wire

Use a jumper wire to bypass an open circuit. A jumper wire is made up of an in-line fuse holder connected to a set of test leads. It should have a five ampere fuse. Never connect a jumper wire across a short circuit. The direct battery short will blow the fuse.

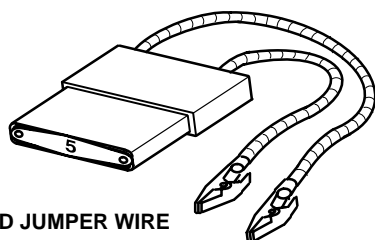

FUSED JUMPER WIRE

Short Finder (Short Circuit Locator)

Short finders are available to locate shorts to ground. The short finder creates a pulsing magnetic field in the shorted circuit which you can follow to the location of the short. Its use is explained on [page 14](#).

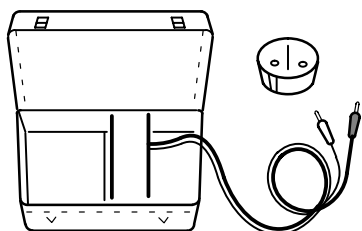

SHORT FINDER

To order any test equipment shown above, contact your local tool supplier. For a list of suppliers and tool numbers, refer to Honda Required Special Tools and Equipment Service Bulletin.

Troubleshooting Precautions

Before Troubleshooting

1. Check the main fuse and the fuse box.
2. Check the battery for damage, state of charge, and clean and tight connections.

CAUTION:

- Do not quick-charge a battery unless the battery ground cable has been disconnected, or you will damage the alternator diodes.
- Do not attempt to crank the engine with the ground cable disconnected or you will severely damage the wiring.

While You're Working

1. Make sure connectors are clean, and have no loose terminals or receptacles.
2. Make sure that connectors without wire seals are packed with dielectric (silicone) grease. Part Number: 08798-9001.

Pack with dielectric (silicone) grease

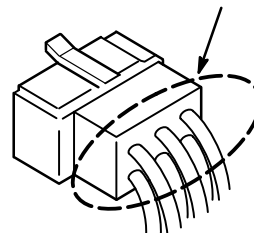

3. When connecting a connector, push it until it “clicks” into place.

CAUTION:

- Do not pull on the wires when disconnecting a connector. Pull only on the connector housings.
- Most circuits include solid-state devices. Test the voltages in these circuits only with a 10-megaohm or higher impedance digital multimeter. Never use a test light or analog meter on circuits that contain solid-state devices. Damage to the devices may result.

How To Use This Manual

Troubleshooting Tests

Testing for Voltage

When testing for voltage at a connector without wire seals, you do not have to separate the two halves of the connector. Instead, probe the connector from the back. Always check both sides of the connector because dirty, corroded, and bent terminals can cause problems (no electrical contact = an open).

1. Connect one lead of the test light to a known good ground, or, if you're using a digital volt ohmmeter (DVOM), place it in the appropriate DC volts range, and connect its negative lead to ground.

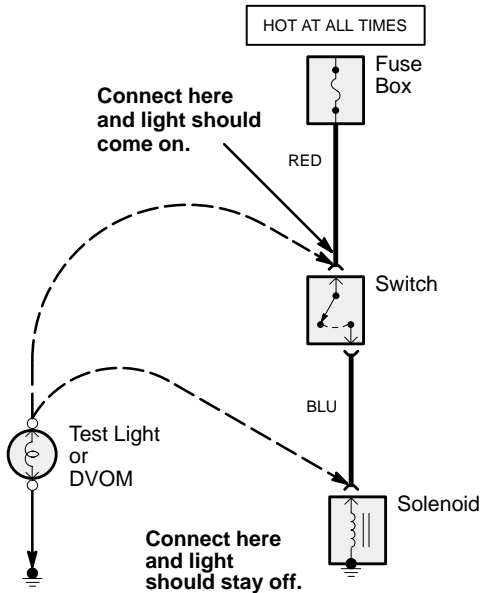

2. Connect the other lead of the test light or DVOM to the point you want to check.
3. If the test light glows, there is voltage present. If you're using a DVOM, note the voltage reading. It should be within one volt of measured battery voltage. A loss of more than one volt indicates a problem.

NOTE: Always use a DVOM on high impedance circuits. A test light may not glow (even with battery voltage present).

Testing for Continuity

When testing for continuity at a connector without wire seals, you do not have to separate the two halves of the connector. Instead, probe the connector from the back. Always check both sides of the connector because dirty, corroded, and bent terminals can cause problems (no electrical contact = an open).

1. Disconnect the negative cable from the car battery. If you're using a DVOM, place it in the lowest "OHMS" range.
2. Connect one lead of a self-powered test light or DVOM to one end of the part of the circuit you want to test.

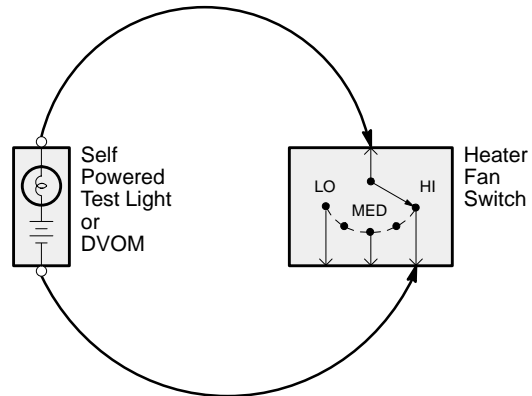

3. Connect the other lead to the other end.
4. If the self-powered test light glows, there is continuity. If you're using a DVOM, a low reading or no reading (zero), means good continuity.



How To Use This Manual

– Troubleshooting Tests

Testing for Voltage Drop

Wires, connectors, and switches are designed to conduct current with a minimum loss of voltage. A voltage drop of more than one volt indicates a problem.

1. Place the digital volt/ohmmeter (DVOM) in the appropriate DC volts range. Connect the positive lead to the end of the wire (or to the connector or switch) closest to the battery.

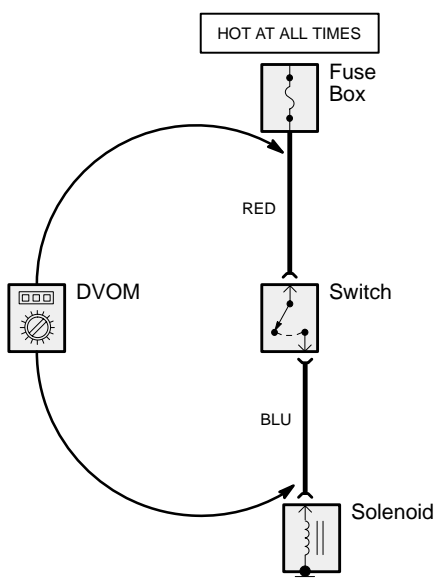

2. Connect the negative lead to the other end of the wire (or the other side of the connector or switch).
3. Turn on the components in the circuit.
4. The DVOM will show the difference in voltage between the two points. A difference, or drop, of more than one volt indicates a problem. Check the circuit for loose, dirty, or bent terminals.

Testing for a Short with a Test Light or DVOM

1. Remove the blown fuse and disconnect the load.
2. Connect a test light or digital volt/ohmmeter (DVOM), switched to the appropriate DC volts range, across the fuse terminals to make sure voltage is present. You might have to turn the ignition switch to ON; check the schematic to see.

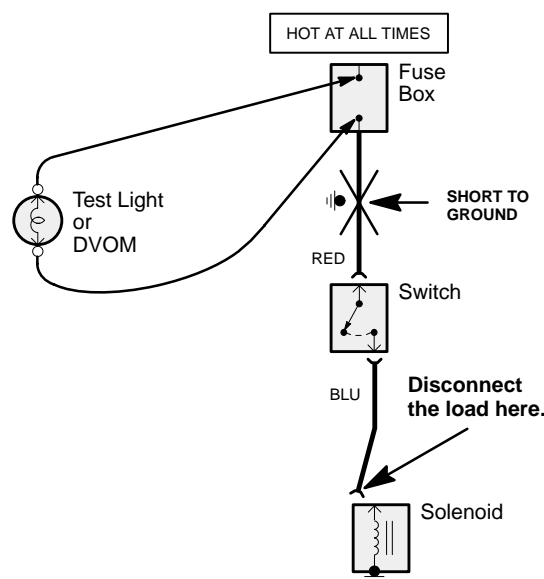

3. Beginning near the fuse box, wiggle the harness. Continue this at convenient points about six inches apart while watching the test light or DVOM.
4. Where the test light goes off, or the DVOM voltage drops to zero, there is a short to ground in the wiring near that point.

NOTE: Always use a DVOM on high impedance circuits. A test light may not glow (even with battery voltage present).

How To Use This Manual

Troubleshooting Tests

Testing for a Short with a Self-Powered Test Light or DVOM

1. Remove the blown fuse and disconnect the battery and load.
2. Connect one lead of a self-powered test light or digital volt/ohmmeter (DVOM) (switched to the lowest "OHMS" range) to the fuse terminal on the load side.

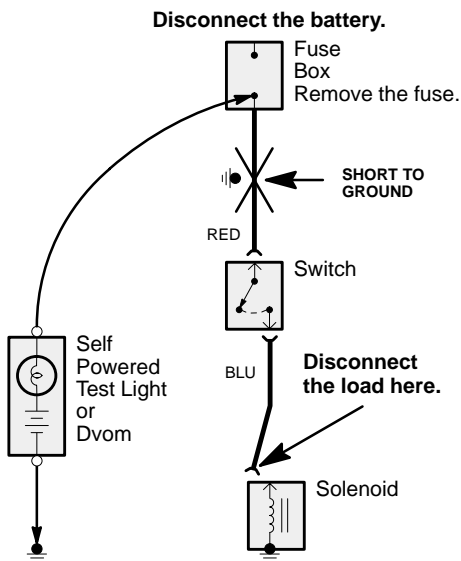

3. Connect the other lead to a known good ground.
4. Beginning near the fuse box, wiggle the harness. Continue this at convenient points about six inches apart while watching the test light or DVOM.
5. If the self-powered test light goes on or the DVOM displays a low reading or no reading (zero), there is a short to ground in the wiring near that point.

Testing for a Short with a Short Circuit Locator (Short Finder)

1. Remove the blown fuse. Leave the battery connected.
2. Connect the short finder across the battery terminals and the load (component) side of the fuse terminal.

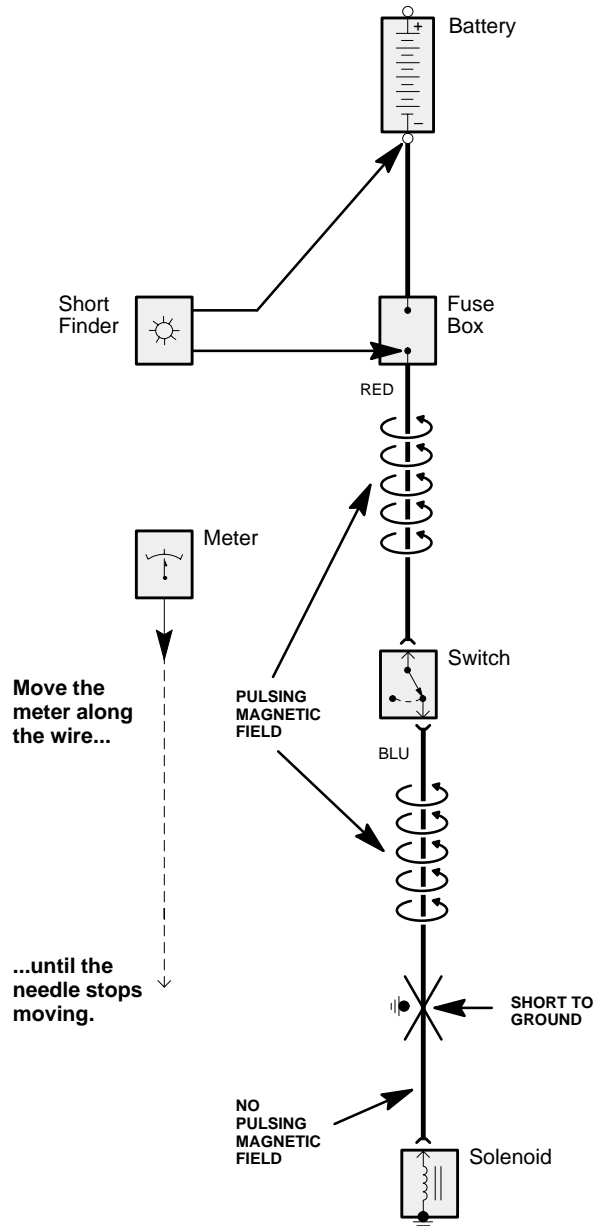

3. Close all switches in the circuit you're testing.



How To Use This Manual

– Troubleshooting Tests

4. Turn on the short finder. This creates a pulsing magnetic field around the wiring between the fuse box and the short.
5. Beginning at the fuse box, slowly move the short finder along the circuit wiring. The meter will read current pulses through sheet metal and body trim. As long as the meter is between the fuse and the short, the needle will move with each current pulse. Once you move the meter past the point of the short, the needle will stop moving. Check the wiring and connectors in this area to locate the cause of the short.