



# INSTALLATION INSTRUCTIONS

Accessory

ENGINE BLOCK HEATER  
P/N 08T44-SV4-100

Application

2002 ACCORD  
2- AND 4-DOOR  
(EXCEPT V6)

Publications No.

All 22918

Issue Date

AUG 2001

## PARTS LIST

Engine block heater



Aluminum washer



Heater harness

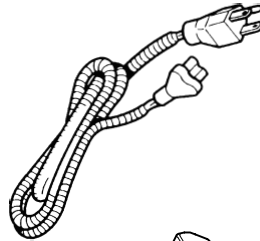

Protective cap

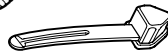

9 Wire ties



## TOOLS AND SUPPLIES REQUIRED

24 mm Socket

Phillips screwdriver

Torque wrench

Drain pan

Antifreeze (Honda Antifreeze/Coolant only, in a 50/50 mixture with water)

### NOTICE

- Always use Honda Antifreeze/Coolant. Using a non-Honda coolant can result in corrosion, causing the cooling system to malfunction or fail.
- To avoid burning out the element, do not operate the engine block heater before it is installed in the vehicle or before you add coolant.

## INSTALLATION

**Customer Information:** The information in this installation instruction is intended for use only by skilled technicians who have the proper tools, equipment, and training to correctly and safely add equipment to your car. These procedures should not be attempted by "do-it-yourselfers."

1. Allow the engine and all cooling system components to cool down.
2. Make sure you have the anti-theft code for the radio, then write down the frequencies for the preset buttons.
3. Disconnect the negative cable from the battery.
4. Place a clean drain pan under the radiator drain plug, then remove the drain plug from the rear of the radiator to drain the coolant. Remove the radiator cap, and loosen the bleed bolt to increase the flow.

### NOTICE

Radiator coolant will damage paint. Quickly rinse any spilled coolant from painted surfaces.

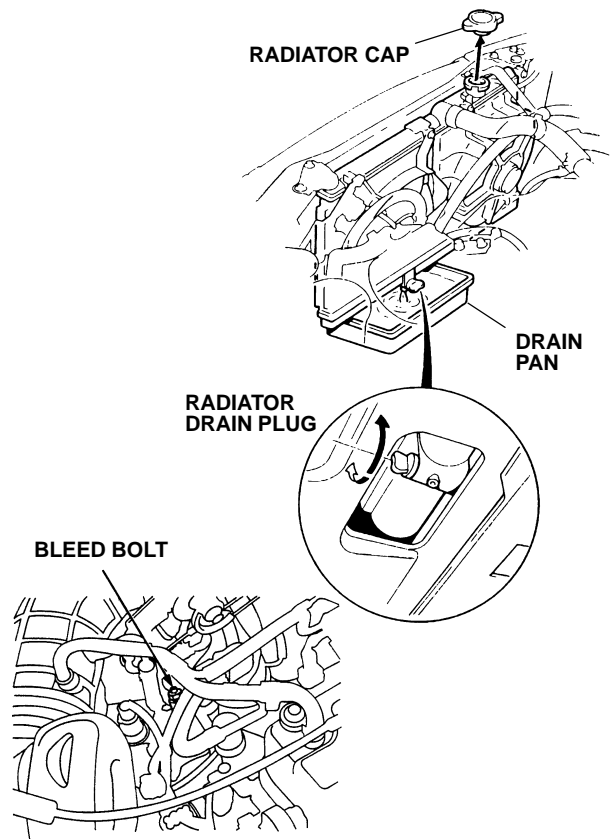

- Remove the bolt with the washer from the engine block on the left side near the oil filter. Coolant remaining in the engine jackets will flow out of the bolt hole when the bolt is removed.

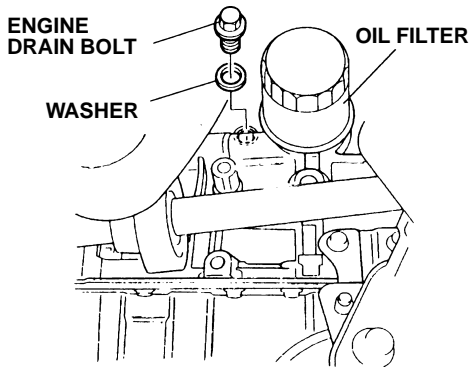

- Install the new aluminum washer and the engine block heater into the bolt hole using a 24 mm socket and a torque wrench. Torque the engine block heater to 60 N·m (44 lb-ft).

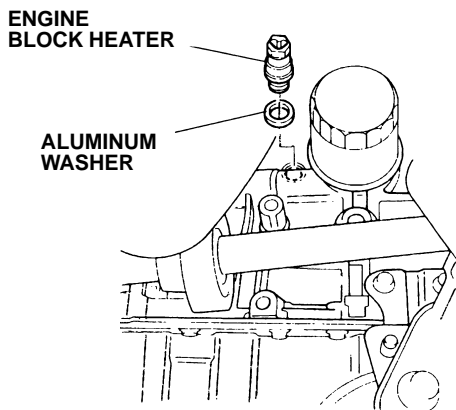

- Plug the connector of the heater harness into the engine block heater, and route the heater harness over the engine.

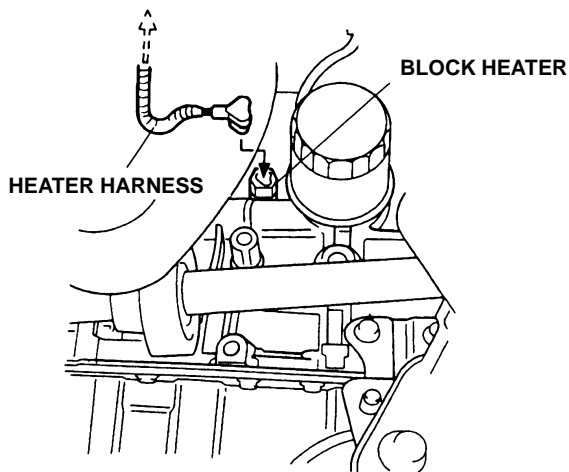

- Route the heater harness alongside the engine harness to the front bumper.

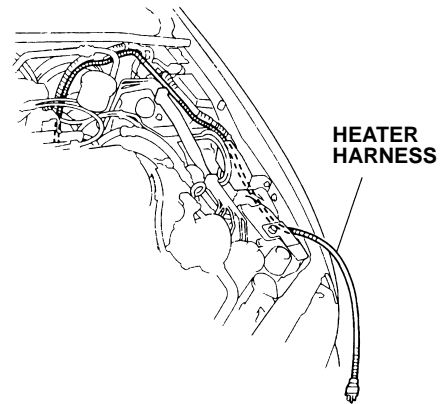

- Remove the left front turn signal, and disconnect the connector.

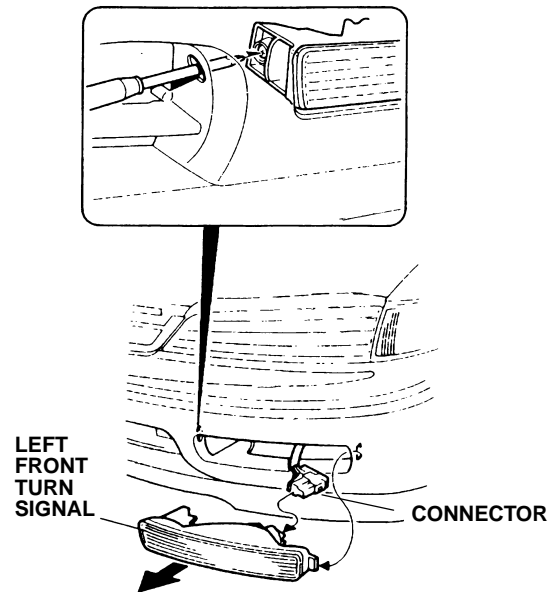

- Continue routing the heater harness toward the front through the hole in the body next to the driver's side headlight.

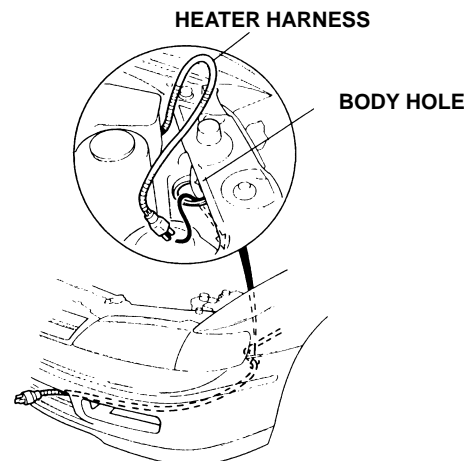

11. Attach the protective cap to the front grille, and plug the connector of the heater harness into the protective cap.

12. Secure the heater harness to the front grille with two wire ties in the areas shown.

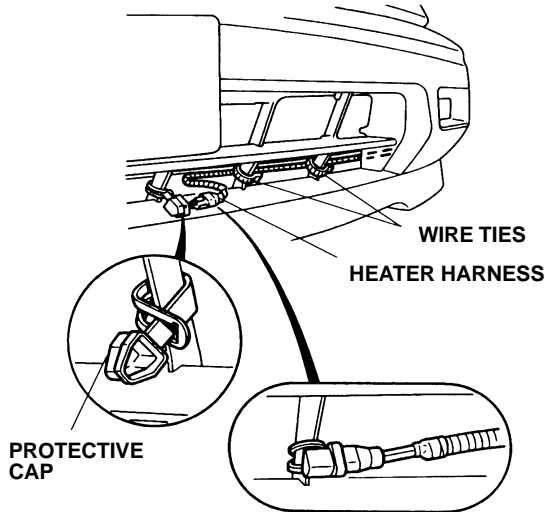

13. Reaching through the left front turn signal hole, secure the wire harness to the vehicle harness with one wire tie.

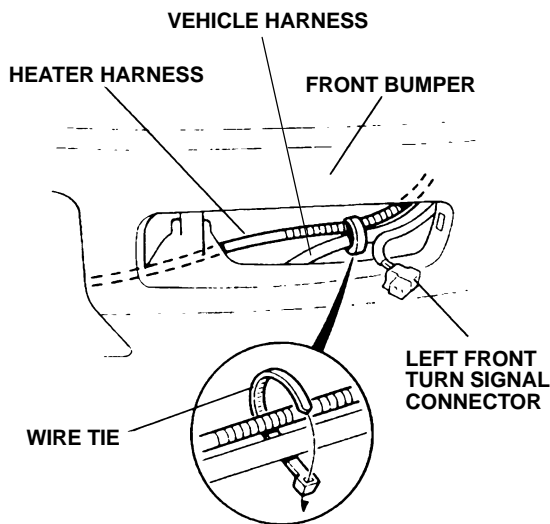

14. Secure the heater harness to the engine harness with six wire ties in the areas shown. Cut the excess off each wire tie.

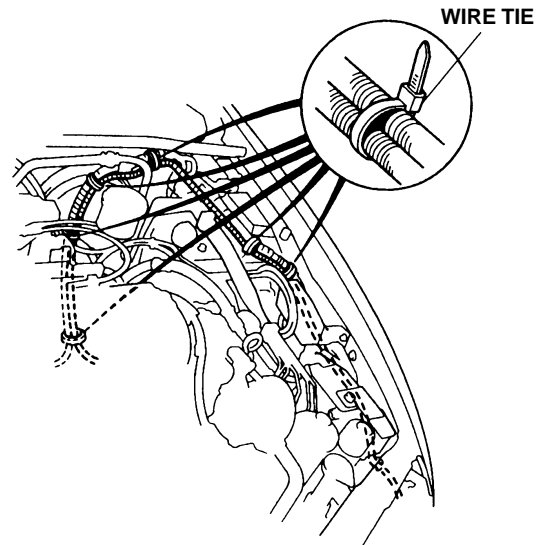

15. Reinstall the left front turn signal, and reconnect the connector.

16. Reconnect the negative cable to the battery.

17. Fill the system with the recommended coolant as described in the service manual.

- Use only Honda Antifreeze/Coolant mixed 50/50 with water.
- Tighten the bleed bolt when coolant flows steadily out of the bleed bolt hole.
- Start the engine, and let it idle for about 10 minutes.
- Stop the engine and recheck the level of the coolant. If necessary, replenish the coolant up to the proper level.
- Loosen the bleed bolt and bleed the system. Tighten the bleed bolt.
- Repeat the above procedures until the correct coolant level is obtained.

18. Check the reserve tank for correct level and signs of leakage. Repair as necessary.

19. Enter the customer's radio anti-theft code, if applicable, and reset the radio station presets.

20. Reset the clock.