



INSTALLATION INSTRUCTIONS

Accessory

TRUNK SPOILER

Application

1997 ACCORD
2- AND 4-DOOR
(INCLUDES V6)

Publications No.

All 18010

Issue Date

SEP 1996

PARTS LIST

Trunk spoiler

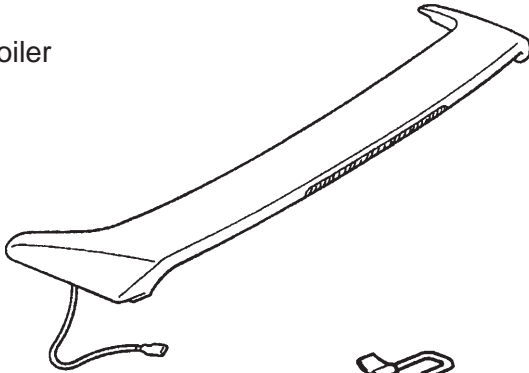

Right trunk spring
(marked red)



Left trunk spring
(marked yellow)

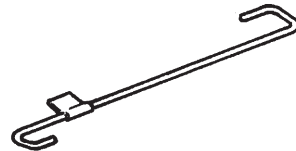

Template

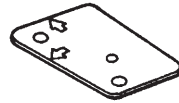

Spoiler harness

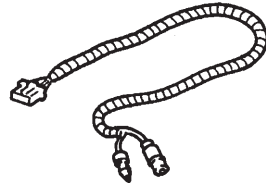

4 Bolts, 6 x 8 mm



4 Plastic washers



7 Long wire ties

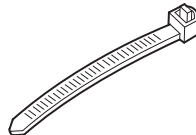

4 Short wire ties

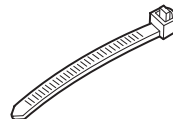

TOOLS AND SUPPLIES REQUIRED

#2 Phillips screwdriver

Flat tip screwdriver, small

Eye protection (face shield, safety goggles, etc.)

Drill

3 mm, 6 mm, 8 mm, and 10 mm Drill bits

10 mm Combination wrench

Felt-tip pen

Center-punch

File

Touch-up paint

Hammer

Piece of wire

10 mm Socket

Torque wrench

Heavy gloves

Trunk Spring Installer/Remover:

T/N 08M10-SM4-100

INSTALLATION

Before You Begin:

- Write down the customer's radio station presets; the radio memory will be erased when you disconnect the battery.
- If the radio has a coded theft protection circuit, be sure you have the anti-theft code before you disconnect the battery.
- Be sure the area to be covered is clean and waxed with a high-quality paste wax.

1. Disconnect the negative cable from the battery.
2. Inside the trunk lid, locate the two identification holes on the trunk lid. If necessary, scrape away the seam sealer so you can see the outline of the holes. Mark and lightly center-punch the center of the holes. Repeat on the other side.

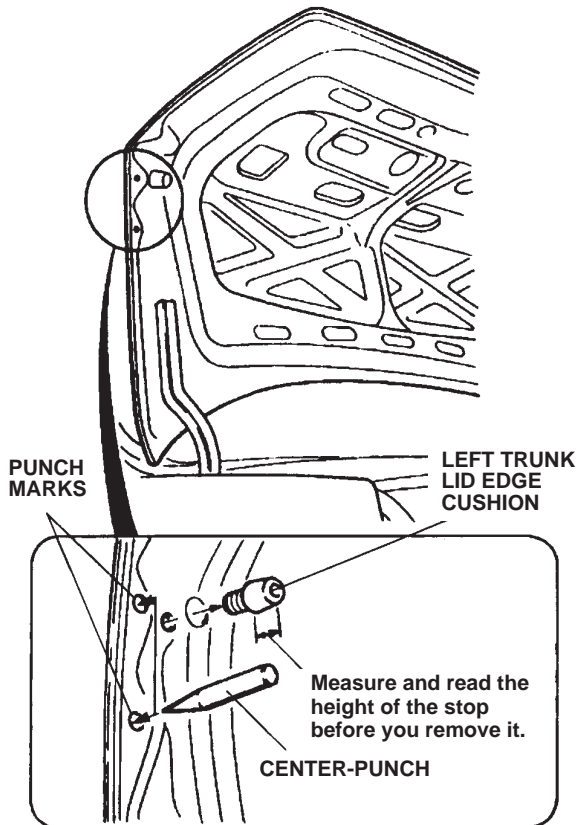

3. Locate the left trunk lid edge cushion; measure and record the height of the cushion, then remove the cushion.

4. Have an assistant hold the trunk lid open. While wearing eye protection, drill an 8 mm hole through each mark:
 - First drill with a 3 mm bit, then a 6 mm bit, and finally with an 8 mm bit.
 - Remove all burrs and metal shavings, and apply touch-up paint to the edges of the holes.
 - Repeat on the other side.

First drill pilot holes with 3 mm and 6 mm bits, then finish with an 8 mm bit.

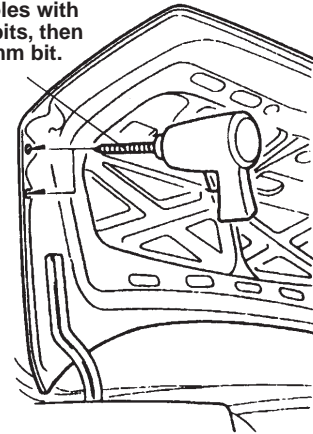

5. Close the trunk lid. Position the template, printed side up, at the left (driver's side) edge of the trunk lid. Align the two outer holes in the template with the two holes in the trunk lid. Using a felt-tip pen, mark the trunk lid as indicated on the template. The right side of the trunk lid does not need a hole; mark only the left side for the spoiler harness. Remove the template, and lightly center-punch the mark.

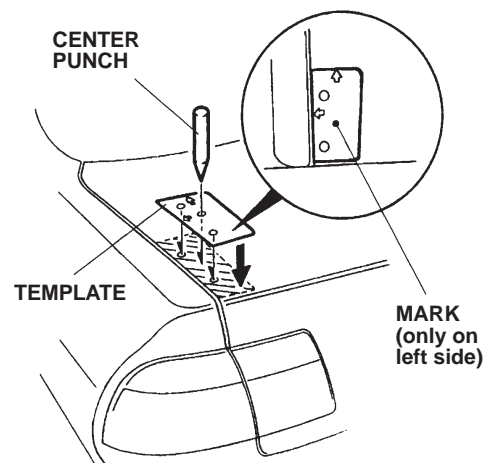

6. While wearing eye protection, drill a 10 mm hole at the center-punched mark through the outer skin of the trunk lid; do not drill through the inner panel:

- Drill first with a 3 mm bit, then with a 6 mm bit, next with an 8 mm bit, and finish with a 10 mm bit.
- Remove all burrs and metal shavings, and apply touch-up paint to the edge of the hole you drilled.

This hole is for routing the spoiler harness through the trunk lid.

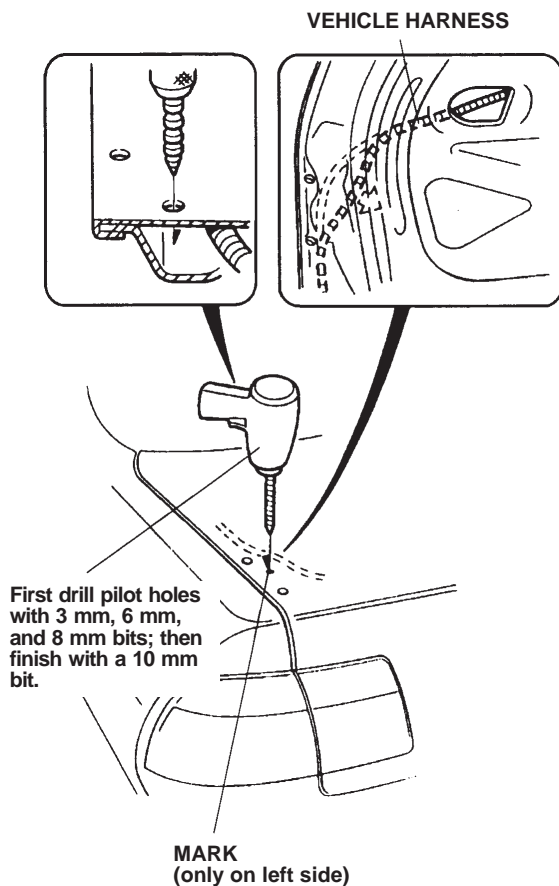

7. Hold the spoiler above the trunk, and route the harness from the spoiler down through the 10 mm hole you just drilled. Then route it through the rectangular hole as shown. Use a piece of wire if necessary. Install the four bolts and four plastic washers, and tighten them to 7-10 N·m (5-7 lb-ft).

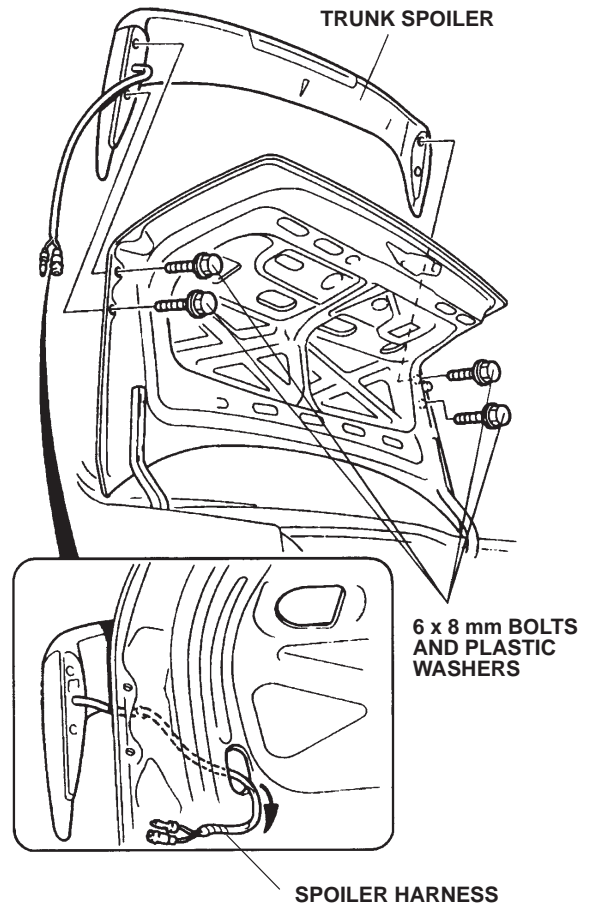

8. Reinstall the left trunk lid edge cushion, and adjust it to the height you recorded in step 3.

9. With an assistant holding the trunk lid open, remove the old trunk springs from the trunk hinge arms using the special tool. Wear heavy gloves to protect your hands, and pull the special tool slowly and carefully toward you.

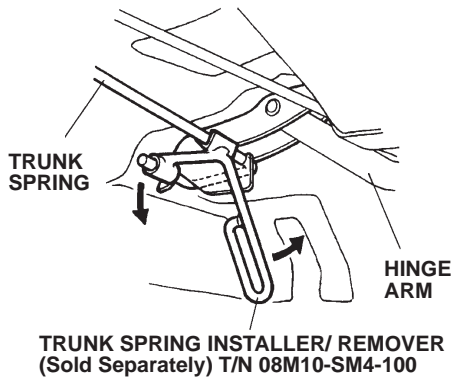

10. Install the new heavy-duty springs in the reverse order of removal:
- Set the tool on the unmarked end of each trunk spring.
 - Install the red-marked spring starting with the hole in the spring at the right (passenger's) side of the vehicle; install the yellow-marked spring starting on the left (driver's) side.
 - Wearing gloves, rotate the tool as you pull it toward you.
 - Set the springs into the first notch (original position) of the hinge arms.
 - Reinstall the center clip on the trunk springs.

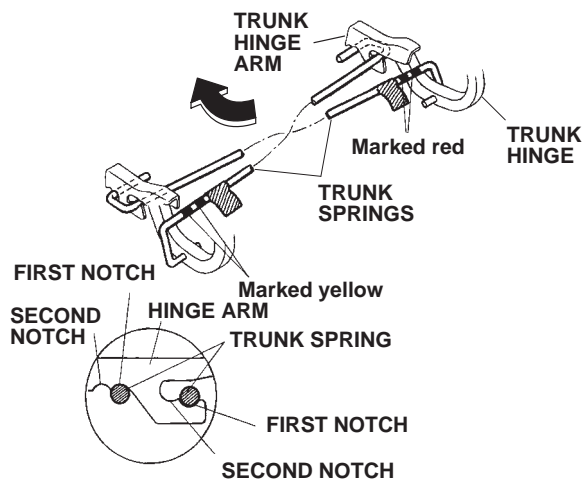

Routing the Wire Harness

11. Unplug the high-mount brake light 2-pin connector. Route the brake light harness over the trunk spring, and connect the spoiler harness 2-pin connector to the brake light harness 2-pin connector.

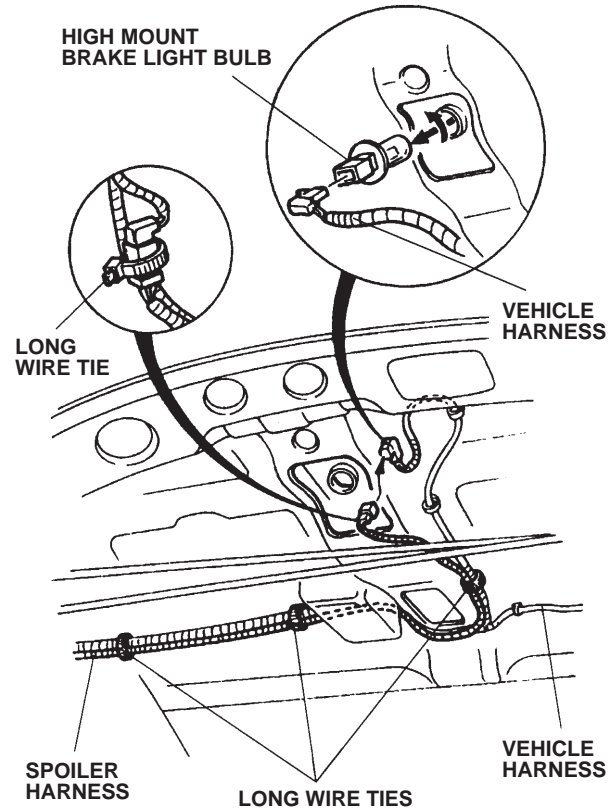

12. Secure the spoiler harness to the vehicle harness with four long wire ties.

- Route the spoiler harness along the vehicle harness, and secure the spoiler harness to the vehicle harness with the remaining three long wire ties in the areas shown.

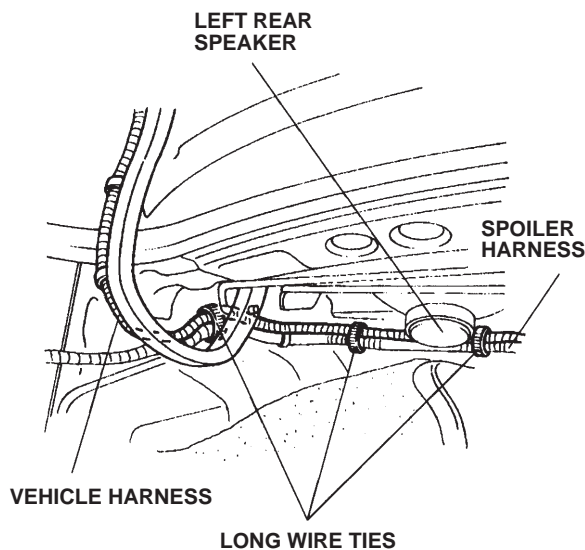

- Connect the spoiler terminals to the spoiler harness terminals.
- Route the spoiler harness along the vehicle harness secured to the trunk hinge arm. Secure the spoiler harness to the vehicle harness with the four short wire ties in the areas shown, then tuck the spoiler terminals back in the hole in the trunk lid.

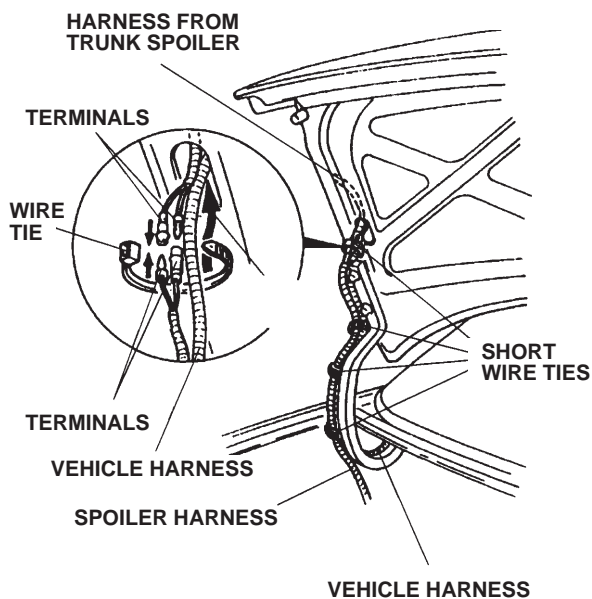

- Check that all wire harnesses are routed properly and that all connectors are plugged in.
- Reconnect the negative cable to the battery.
- Enter the customer's radio anti-theft code if applicable, and reset the radio station presets.
- Reset the clock.
- Check that the spoiler brake light comes on when the brake pedal is pressed.

Use and Care

- Handle the spoiler with care. It is not designed to absorb impact.
- Check the spoiler mounting bolts periodically, and retighten them if necessary.