

**INSTALLATION
INSTRUCTIONS**

Accessory

KEYLESS ENTRY

Application

**1999 ACCORD (LX)
2- AND 4-DOOR
(INCLUDES V6)**

Publications No.

All 20009

Issue Date

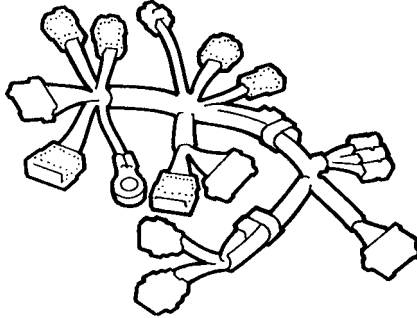
SEP 1998**PARTS LIST****Keyless Entry Attachment:
P/N 08E65-S84-100**Keyless entry wire
harness

Sub-harness

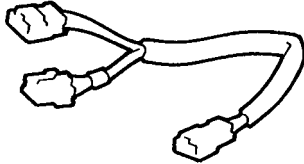

Control unit bracket

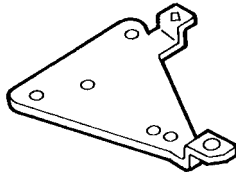

2 Relay brackets

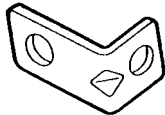

3 Short wire ties



3 Washer-bolts, 6 x 12 mm



Ground bolt



3 Flange nuts, 6 mm



3 Self-tapping screws



Wire tie with clip

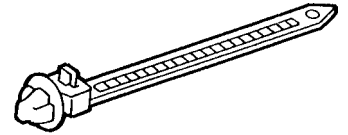

8 Long wire ties

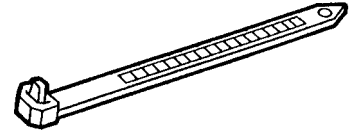

Connector clip



Relay, 4-pin

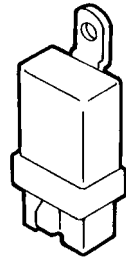

Relay, 5-pin

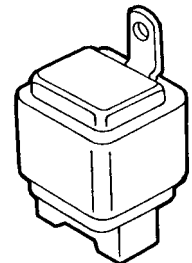

Fuse labels

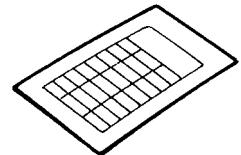

**Keyless Entry System:
P/N 08E61-S84-100**

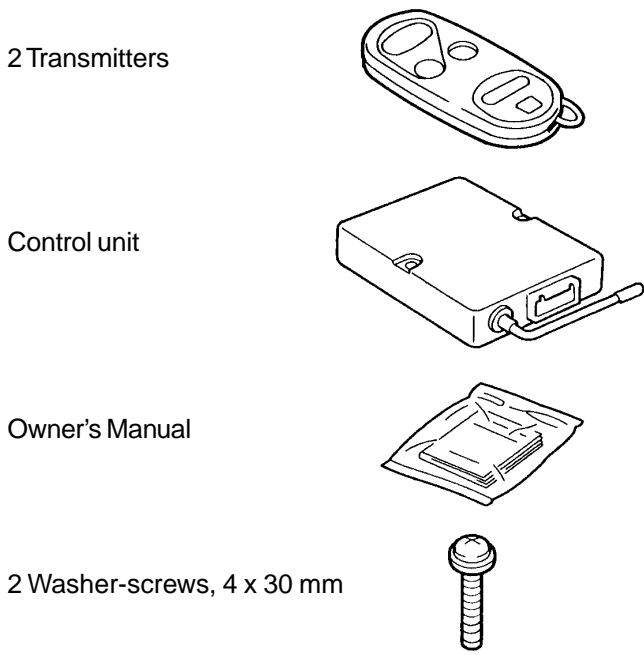

TOOLS AND SUPPLIES REQUIRED

- Small flat-tip screwdriver
- #2 Phillips screwdriver
- Tape measure
- File
- Felt-tip pen
- Pliers
- 17 mm Combination wrench
- 10 mm Socket wrench
- Ratchet
- Utility knife

Illustration of the Keyless Entry Installed on the Vehicle

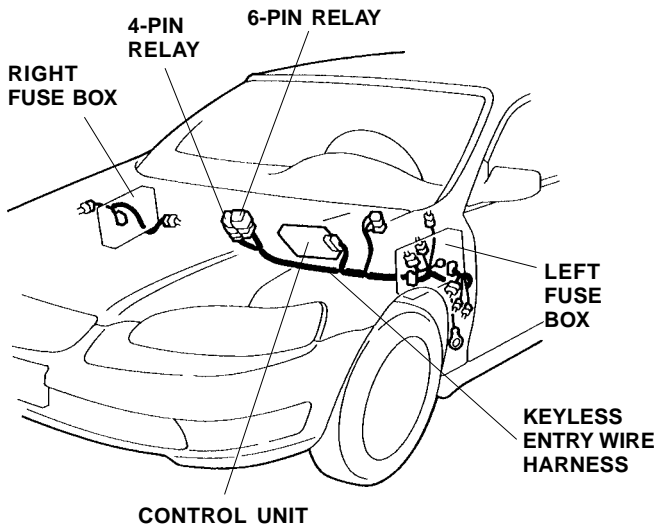

INSTALLATION

Customer Information: The information in this Accessory Installation Instruction is intended for use only by skilled technicians who have the proper tools, equipment, and training to correctly and safely add equipment to your car. These procedures should not be attempted by "do-it-yourselfers."

1. Make sure you have the anti-theft code for the radio, then write down the frequencies for the preset buttons.
2. Disconnect the negative cable from the battery.
3. Inside the passenger compartment, remove the front console lower cover (four retaining clips).

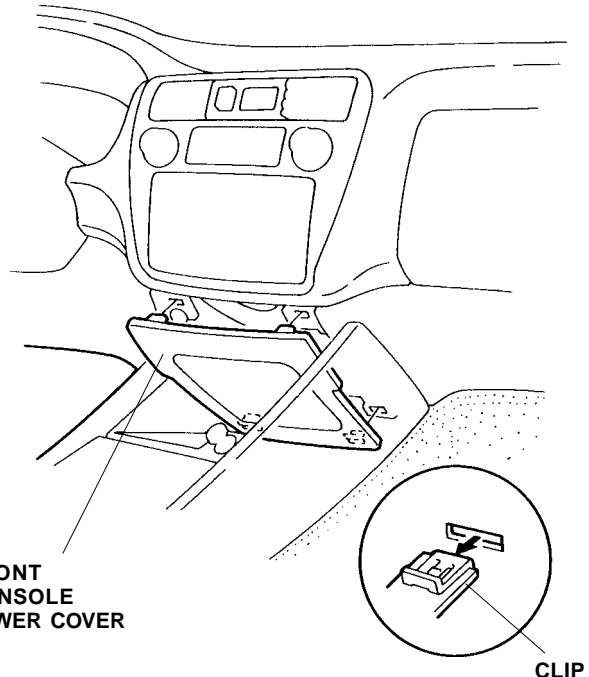

If the vehicle you're working on is equipped with an optional ashtray with cigarette lighter, continue with step 4; if not, go to step 5.

4. Remove the ashtray with cigarette lighter (two self-tapping screws, one connector, and four retaining clips).

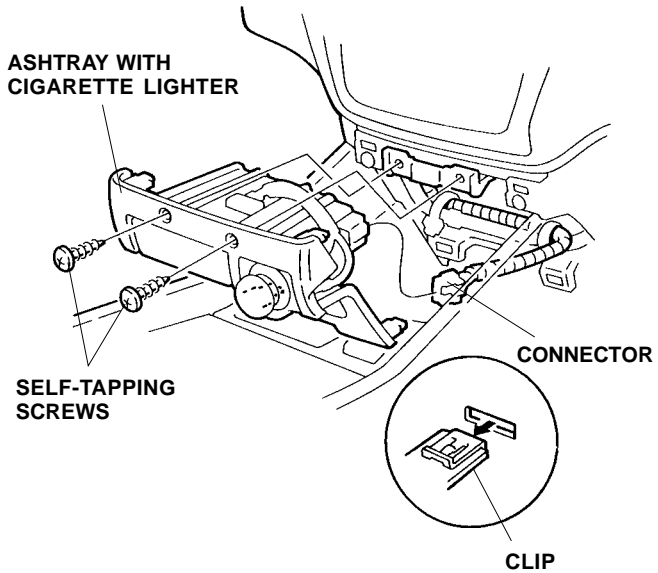

5. Remove the left fuse box cover (three clips and two tabs).

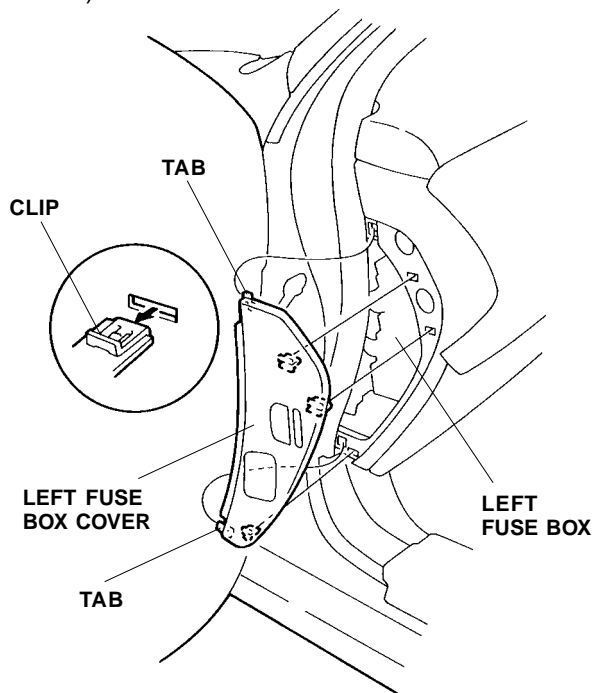

6. Remove the driver's dashboard lower cover (three screws and five retaining clips).

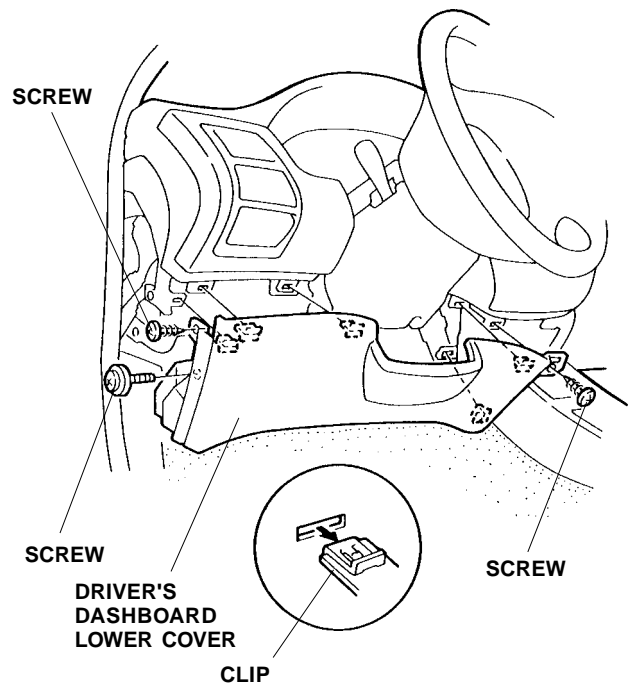

7. Remove the driver's door sill molding (four clips).

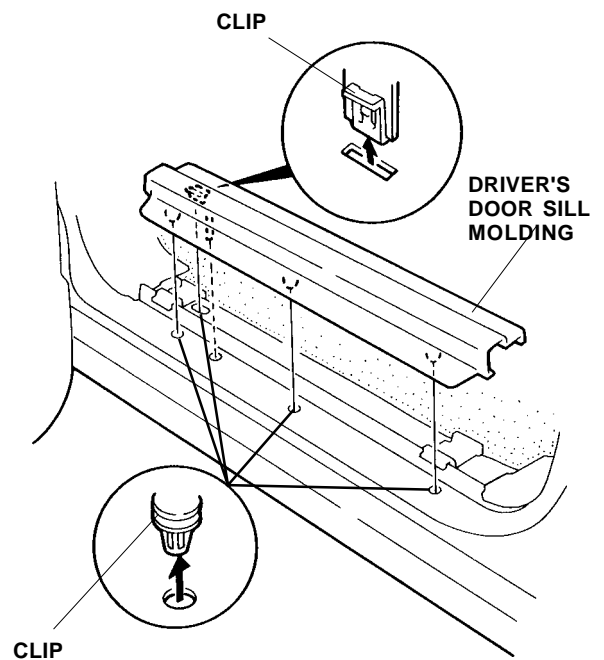

8. Remove the kick panel (two clips, and pull).

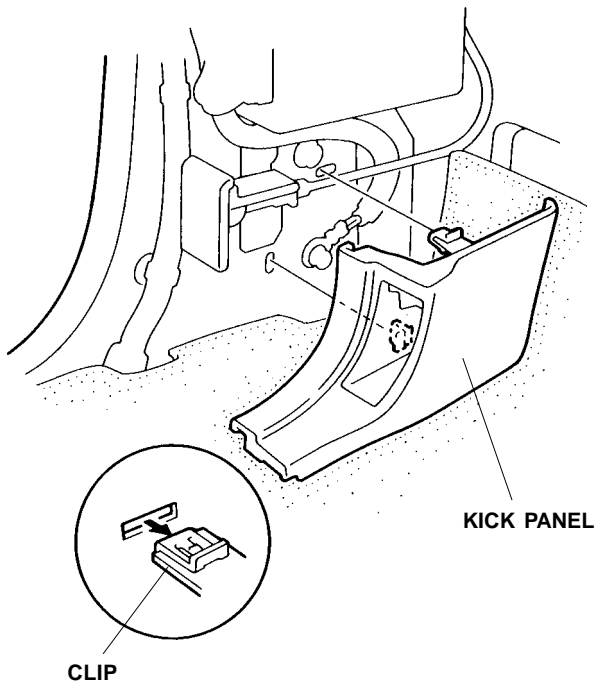

9. Remove the right fuse box cover (three retaining clips and two tabs).

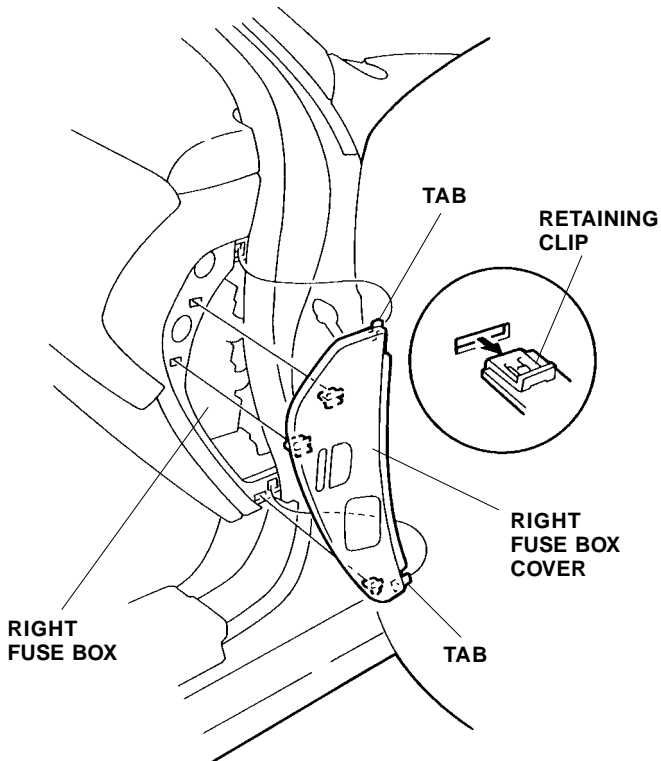

10. Remove the passenger's dashboard lower cover (three screws and seven retaining clips).

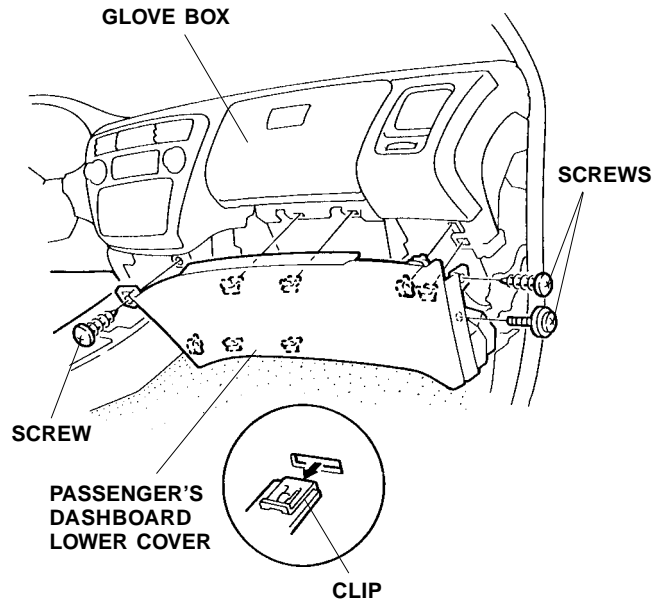

11. Open the glove box, and remove the two screw caps and seven self-tapping screws. Unplug the connector, and remove the glove box by pulling it toward you.

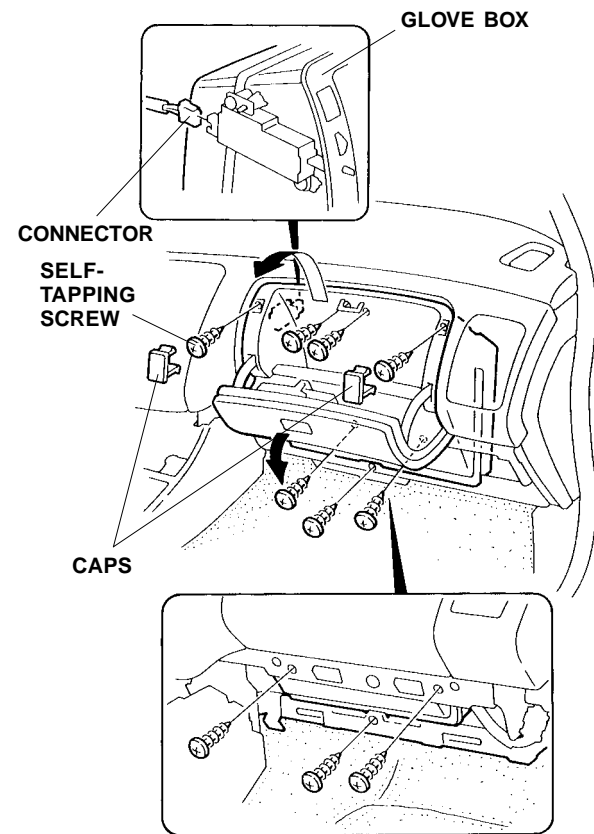

- Push the wire tie with clip into the hole in the back of the control unit bracket. Position the control unit bracket on the driver's dashboard lower cover, and install the three self-tapping screws from the kit.

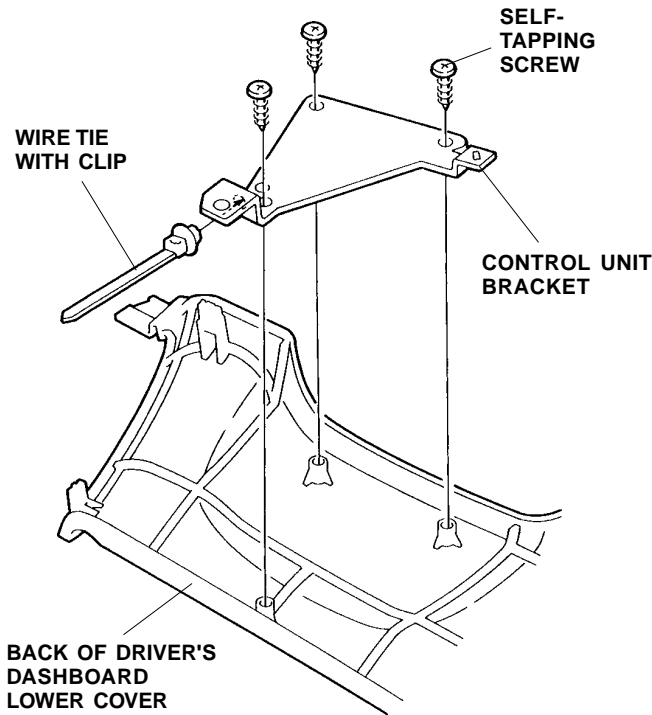

- Position the control unit on the control unit bracket, and install the two 4 x 30 mm washer-screws. Secure the antenna to the control unit bracket with the wire tie with clip you just installed. Secure the antenna to the control unit bracket, parallel with the control unit.

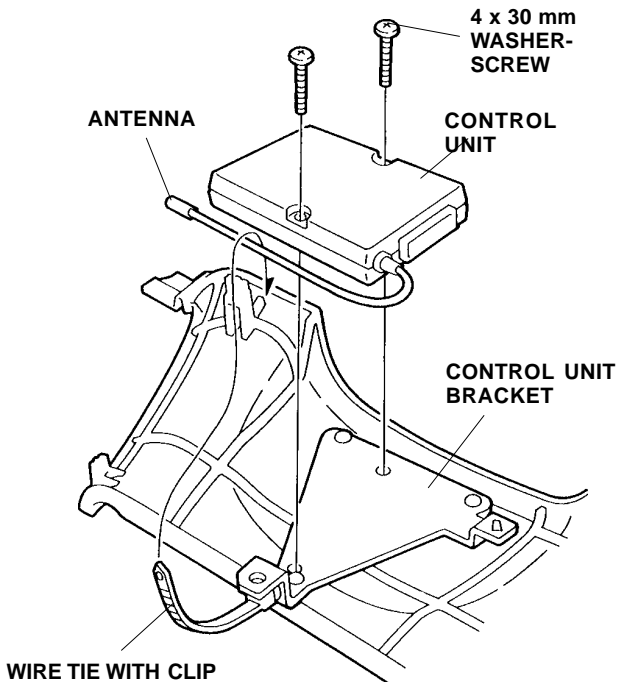

- From the driver's side, route the 14-pin connectors of the keyless entry wire harness to the left fuse box. Unplug the vehicle harness 14-pin connector from the fuse box, and plug the 14-pin connectors of the keyless entry wire harness in between.

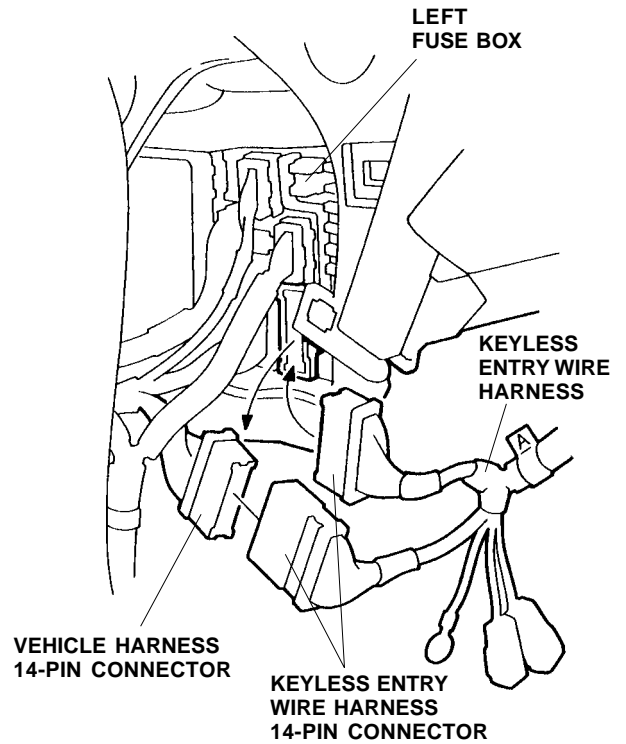

- Secure the 14-pin connector of the keyless entry wire harness to the side of the vehicle connector.

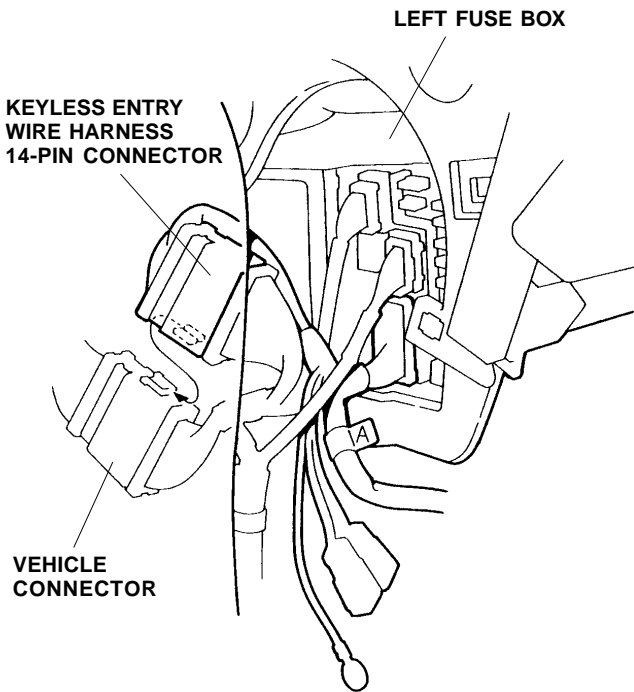

- Locate the two 2-pin connectors blue-taped to the vehicle harness, and remove the blue tapes to free the connectors. Plug the 2-pin connectors you just freed into the 2-pin connectors of the keyless entry wire harness. Connect the blue 2-pin connector of the vehicle harness into the blue 2-pin connector of the keyless entry wire harness.

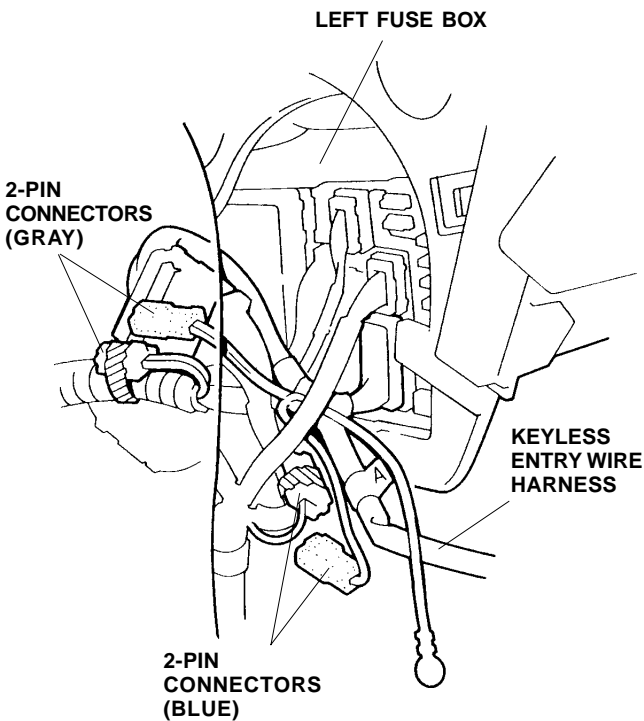

- Remove and discard the upper bolt that fastens the engine hood opener, and attach the ground terminal of the keyless entry wire harness with the ground bolt from the kit.

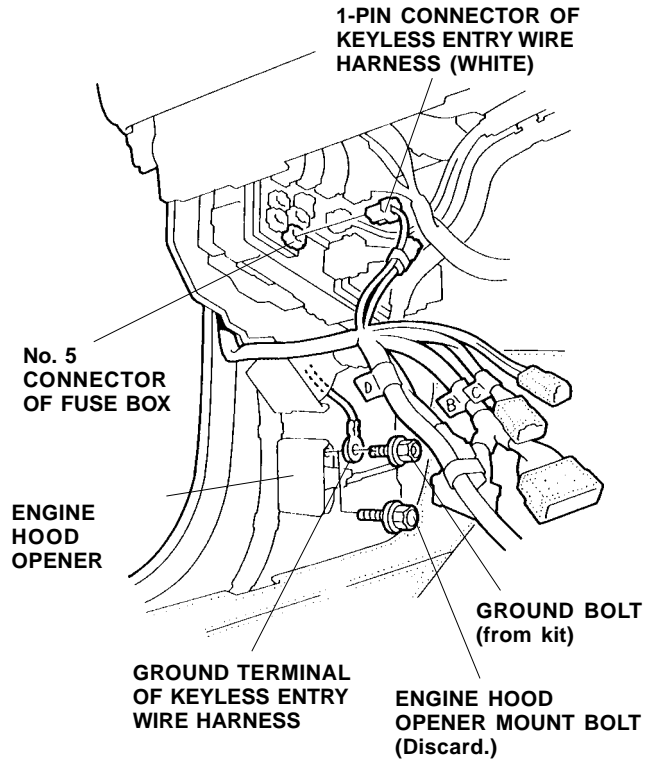

- Plug the 1-pin connector (white) of the keyless entry wire harness into the No. 5 connector of the fuse box.

19. Under the dashboard at the fuse box, locate the 4-pin connector blue-taped to the vehicle harness (22-pin connector), and remove the blue tape to free the connector. Connect the 4-pin connector you just freed to the 4-pin connector (C) of the keyless entry wire harness.

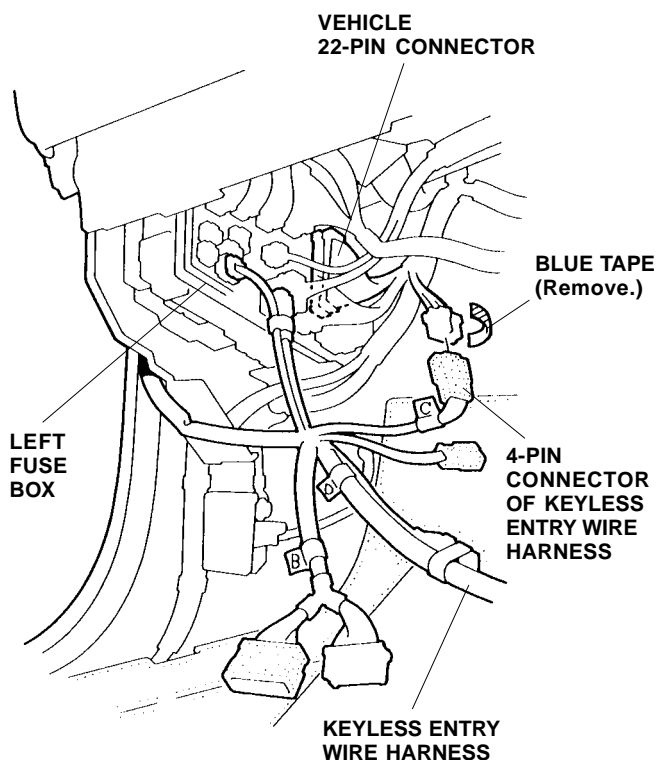

20. Unplug the 20-pin connector from the left fuse box, and plug the two 20-pin connectors (white) of the keyless entry wire harness in between.

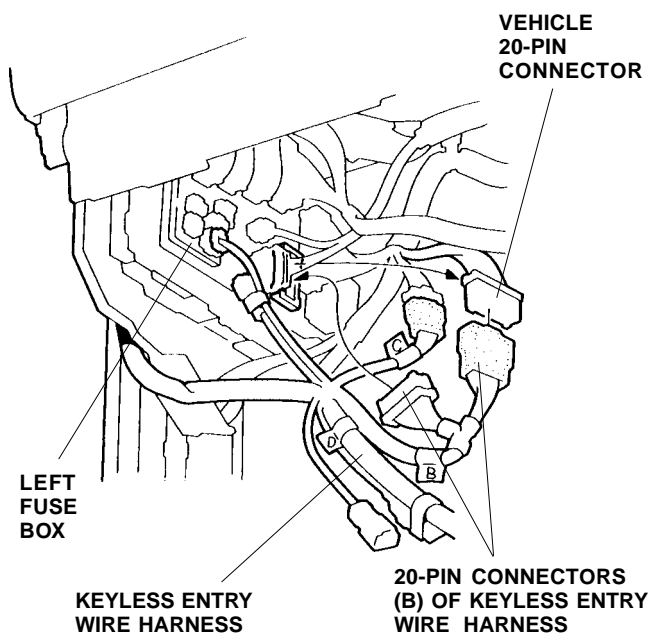

21. Locate the 2-pin connector blue-taped to the vehicle harness 18-pin connector, and remove the blue tape to free the connector. Connect the 2-pin connector you just freed to the 2-pin connector of the keyless entry wire harness.

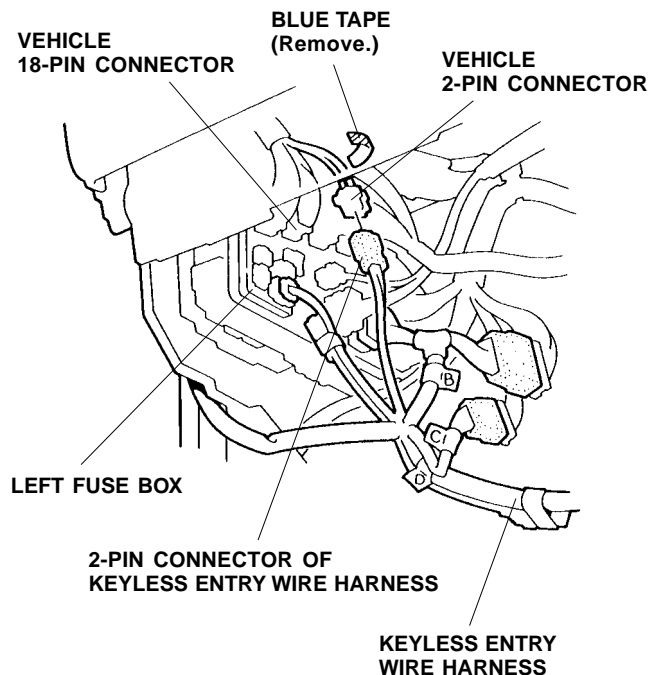

22. Remove the clip from the hole in the left knee bolster; then use a utility knife to cut and discard the clip from the vehicle harness. Take care not to damage the vehicle harness.

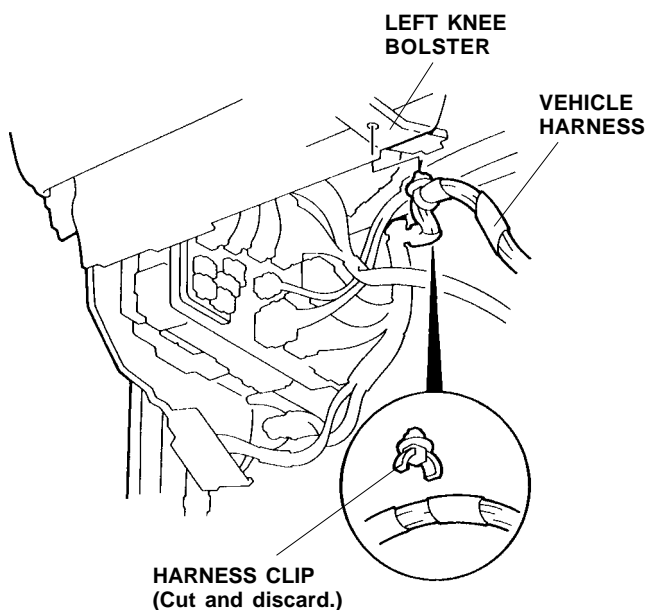

23. Assemble three fuse cases as shown. Attach the appropriate fuse label to each fuse case of the keyless entry wire harness, then attach the connector clip as shown.

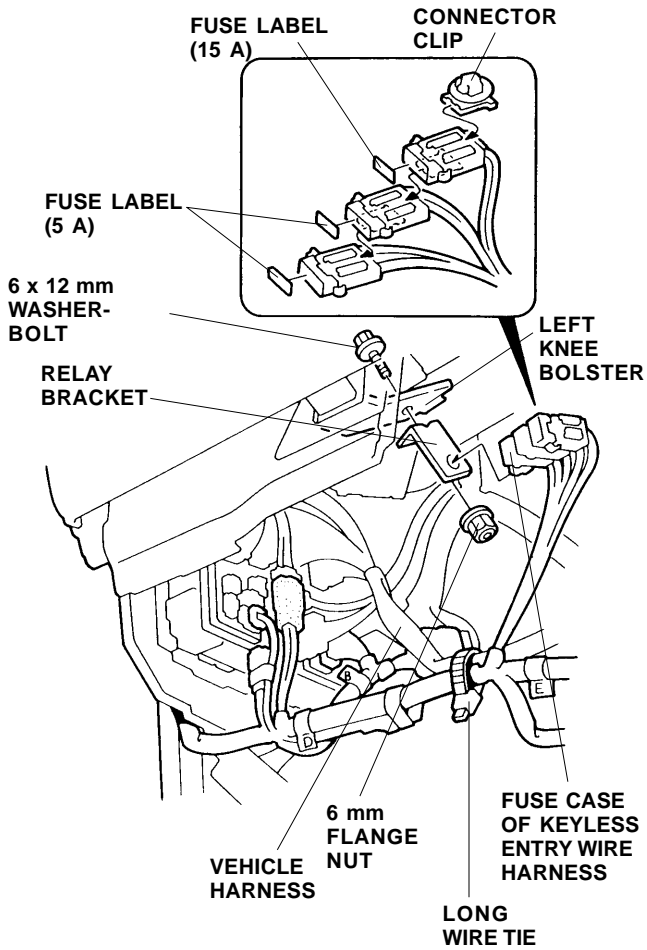

24. Position one relay bracket on the left knee bolster, and install one 6 x 12 mm washer-bolt and one 6 mm flange nut. Push the connector clip on the fuse case of the keyless entry wire harness into the hole in the relay bracket.
25. Secure the keyless entry wire harness to the vehicle harness with one long wire tie in the area shown.

26. Position the 5-pin and 4-pin relays on the relay bracket, and install the 6 mm washer-bolt and 6 mm nut.

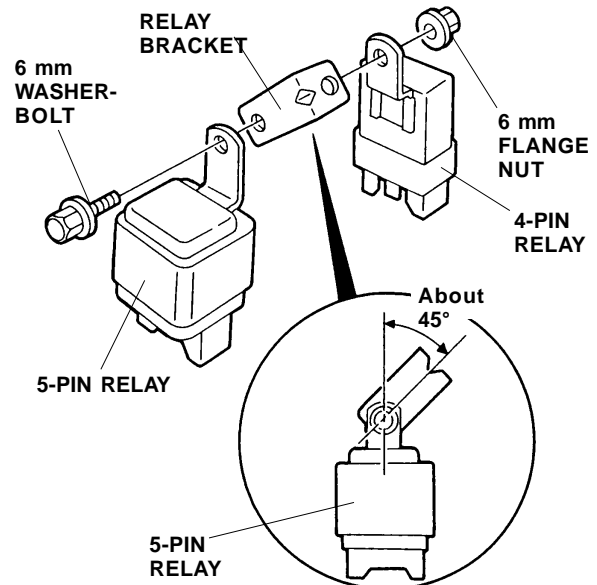

27. Plug the 6-pin and 4-pin connectors of the keyless entry wire harness into the 5-pin and 4-pin relays; then attach the other relay bracket to the steering hanger beam with the other 6 x 12 mm washer-bolt and one 6 mm flange nut.

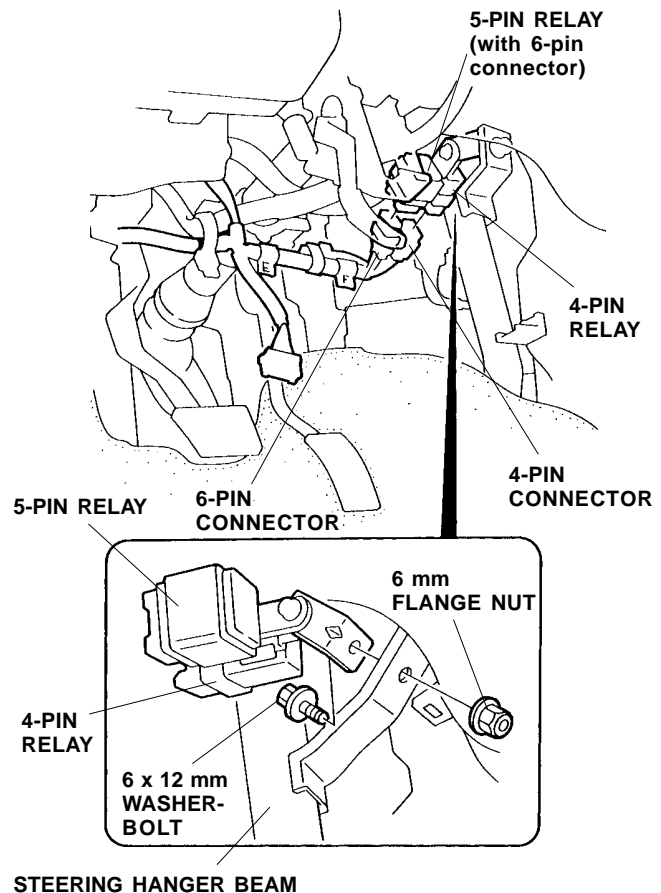

28. Secure the keyless entry wire harness to the vehicle harness with the three short wire ties. Secure the wire ties only in the area shown and not to the yellow SRS harness.

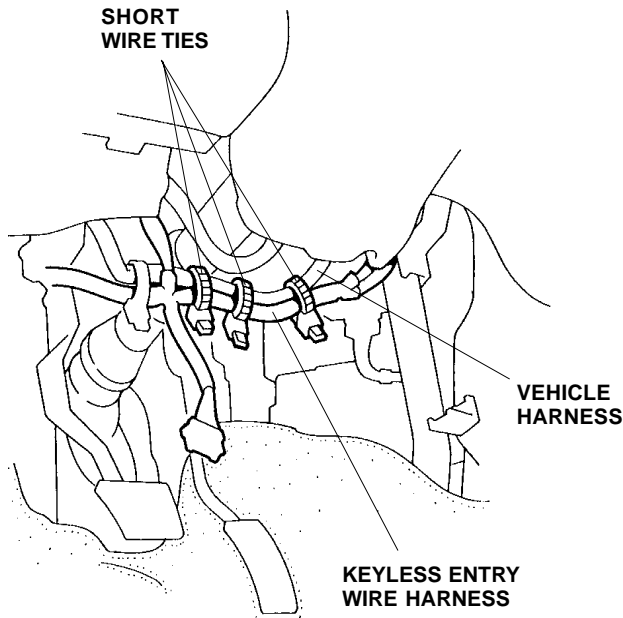

29. On the left side of the steering wheel, secure the keyless entry wire harness to the vehicle harness with three long wire ties in the areas shown.

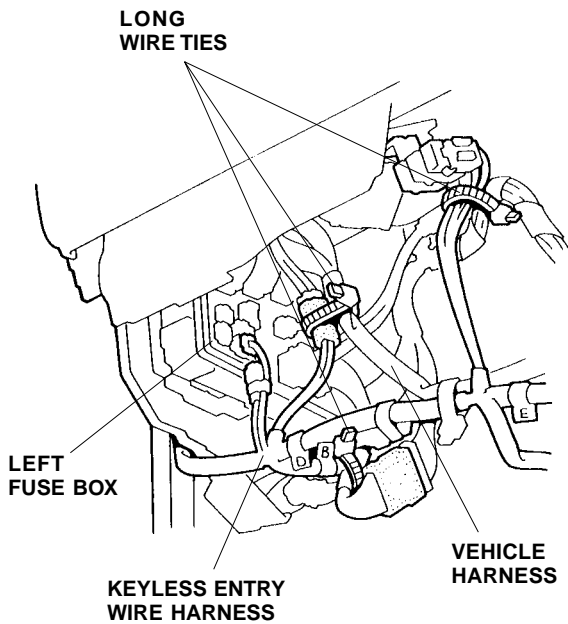

30. On the left fuse box, secure the keyless entry wire harness to the vehicle harness with two long wire ties.

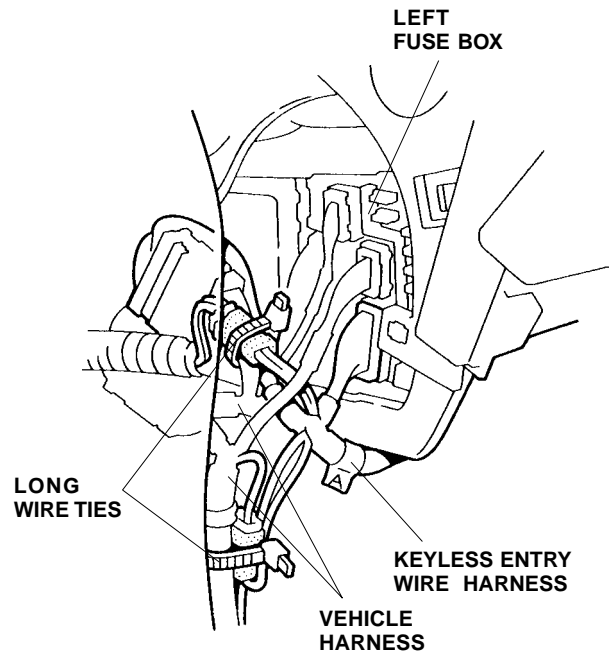

31. Plug the 22-pin connector of the keyless entry wire harness into the control unit, and reinstall the driver's dashboard lower cover.

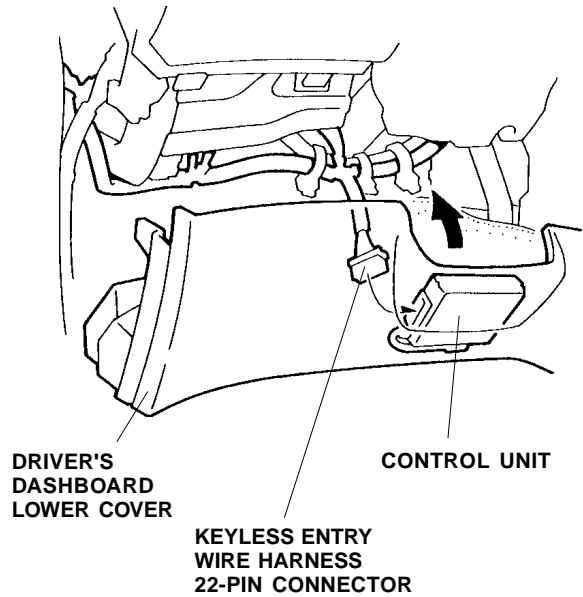

32. Unplug the 4-pin connector from the right fuse box, and plug the 4-pin connectors of the sub-harness there.

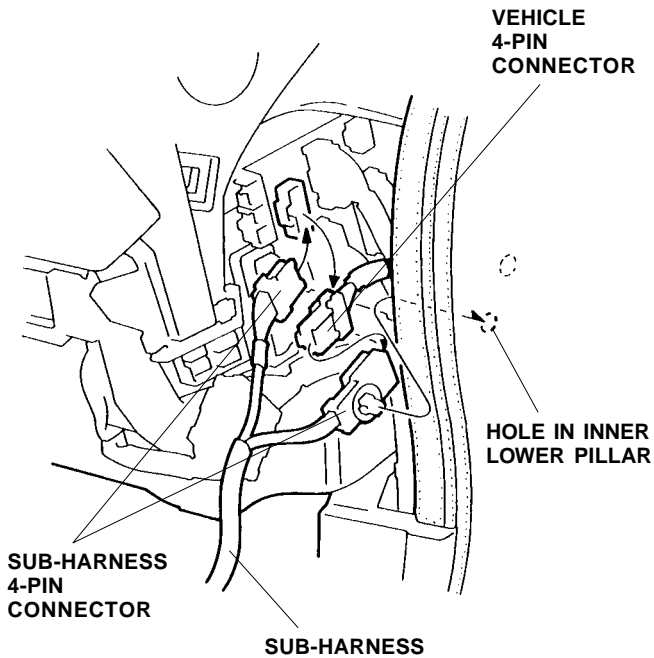

33. Push the clip of the sub-harness 4-pin connector into the hole in the right front inner lower pillar.

34. Route the sub-harness along the vehicle harness. Inside the glove box, locate the 2-pin connector blue-taped to the vehicle harness, and remove the blue tape to free the connector. Plug the 2-pin connector of the sub-harness into the 2-pin connector you just freed.

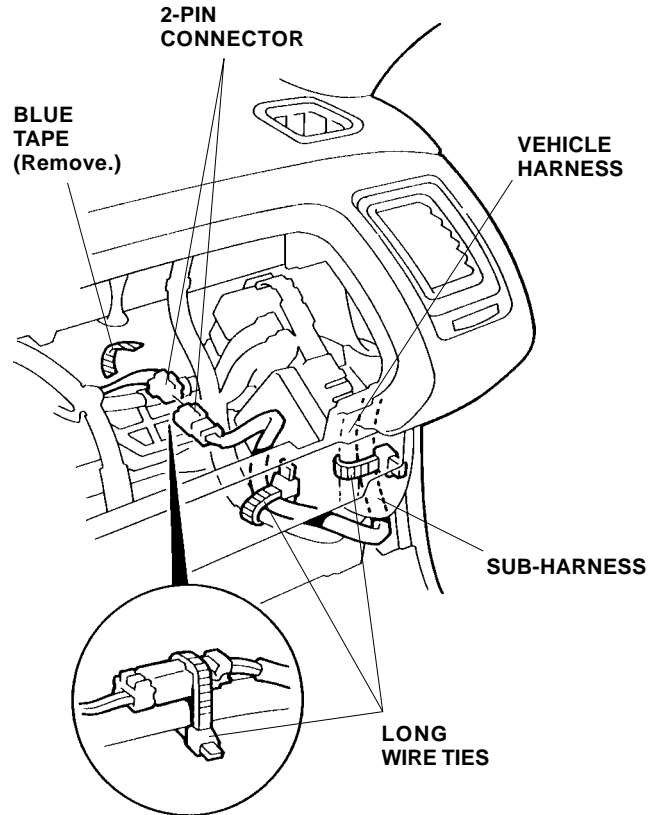

35. Secure the sub-harness to the vehicle harness with three long wire ties in the areas shown.
36. Check that all wire harnesses are routed properly and all connectors are plugged in.
37. Reinstall all removed parts.
38. Reconnect the negative cable to the battery.
39. Enter the customer's radio anti-theft code, if applicable, and reset the radio station presets.
40. Reset the clock.
41. Check operation of the keyless entry system according to the owner's manual supplied.